



INSTALLATION AND PROGRAMMING MANUAL

AFP-300/400

**INTELLIGENT FIRE
DETECTION AND
ALARM SYSTEM**

**SOFTWARE VERSION 2.2
REVISION AUS 3**

NSW (Head Office)
7 Columbia Court
Norwest Business Park
Baulkham Hills NSW 2153

Ph: (02) 9899-4155
Fax: (02) 9899-4156

QLD
16 Lucy St
Moorooka
Qld 4104

Ph: (07) 3892-6444
Fax: (07) 3892-6455

VIC
Unit 2 297 Ingles St
Port Melbourne
Vic 3207

Ph: (03) 9681-9929
Fax: (03) 9681-9930

Notifier Inertia Pty Ltd (A.C.N 002 692 962)
A PITTMWAY COMPANY
www.inertia.com.au

Installation	4
OVERVIEW	4
Passwords.....	4
Operating Features	4
Basic System Requirements (SPECS)	5
<i>AFP-400 System Diagram</i>	5
<i>AFP-300/400 Basic termination points</i>	5
Panel Primary requirements	6
Compatible System Components:	6
Compatible Annunciators	7
Initial Installation Tasks.....	7
The Power Supply Connections	8
240Vac- 24Vdc (Resettable/Non resettable) and Battery Connections.....	8
<i>AFP-300/400 Power Supply</i>	8
<i>MPS-400 Battery Charger Supervision</i>	8
Output Relays (on the power Supply)	9
Alarm and Fault Relays (on the Power Supply)	9
RS-232 and RS-485 Circuits	10
Wiring for RS-485 Annunciator Circuits	10
<i>Terminal & ACS Circuits (RS-485)</i>	10
<i>RS-485 Terminal & ACS Connectors</i>	11
Wiring for RS-232 Circuits	11
<i>Remote Printer Connections</i>	11
<i>Remote Terminal Connections</i>	12
Connecting A Laptop in Terminal Mode to Emulate A Printer	12
Connecting a Laptop VIA Verifier 400 to program the Panel.....	12
Analogue Loop Overview	13
Loop wiring Methods and specification	13
<i>Communication SLC Loop</i>	13
<i>Style 4 Loop Wiring</i>	13
<i>Style 6 Loop Wiring</i>	14
<i>Style 7 Loop Wiring</i>	14
Wiring devices on the Loop	15
<i>Wiring Analogue Addressable Detectors</i>	15
<i>Wiring Conventional Circuits (MMX-2)</i>	15
<i>Wiring Control Modules (CMX-2)</i>	16
<i>Wiring Short Circuit Isolator Modules (ISO-X)</i>	16
<i>Wiring Monitor Modules (MMX-101)</i>	16
<i>XP-5M & XP-5C Modules</i>	17
Common fault finding techniques	18
<i>Shield Termination</i>	18
Before connecting the loop	18
<i>The Affects of Capacitance on Ground Faults</i>	19

Programming	20
OVERVIEW	20
Turning the Panel on for the first Time	20
How to enter a 'Default' Program	20
Program Mode Screen	21
Clear Program	21
Autoprogram	21
<i>Duplicate (Dual) Addressing</i>	22
<i>Default Autoprogram Screen</i>	23
<i>Autoprogram Defaults</i>	23
Autoprogram- Device no longer needed	24
Installing a Device	24
Edit a Point.....	24
Modifying a Point.....	24
Editing Multi Detector Mode.....	25
<i>Programming Cooperative Multi-Detector</i>	25
Delete a Point.....	26
Password	26
Message - Change the "SYSTEM NORMAL MESSAGE"	26
Zone Labels	27
Special Zones	27
<i>F5-F6 (TIME CONTROL)</i>	28
<i>F7 (Holiday)</i>	28
System Functions	29
Annunciator selection	30
Annunciator Groups	30
<i>Annunciator Group 1</i>	30
<i>Annunciator Group 2</i>	31
<i>Annunciator Group 3-5</i>	31
<i>Annunciator Group 6 – 8</i>	31
System Check Function	32
Status Change	32
Isolate a Device or Zone	33
Change Sensitivity	33
Clear Verification Counters	33
Clear History	34
Time and Date.....	34
Walk Test	34
Type Codes (ID's)	35
Monitor Module's	35
<i>Type Codes for Monitor Modules</i>	35
Control Module's	36
<i>Type Codes for Control Modules</i>	36
Panel's Monitored Output Circuits	36
Control-By-Event Programming	37
<i>CBE Equation</i>	37
<i>Automatically Change sensitivity</i>	37
Nominal Detector Sensitivity	38
<i>Self Optimising Pre-Alarm</i>	38
Sensitivity Levels for the AFP-400: (Graph).....	39
<i>Sensitivity Levels- Autoprogram Default Tables:</i>	40

Installation

Overview

The AFP-400 is a modular, intelligent Fire Alarm Control Panel (FACP) with an extensive list of powerful features. The CPU module, power supply module, and cabinet combine to create a complete fire control system for most applications such as commercial, residential and industrial buildings. Optional modules mount to the chassis to provide additional output circuits.

Unlike conventional fire control panels, the AFP-300/400 intelligently communicates with each detector and Input/Output module on the entire system. Thus providing accurate information as to the exact point of alarm and the ability to operate specific outputs using programmable logic functions. The method of communication with field devices is a high-speed proprietary protocol capable of supporting up to 99 detectors and 99 modules per two-wire loop.

The AFP-300 panel is capable of 1 loop and the AFP-400 is capable of 2 loops. Each of the panels can also accommodate up to 10 Annunciators, each can provide 32 x fully programmable LED indications, 16 x single pushbutton functions, 8 x relay outputs, remote LCD displays etc.

These systems due to their immense flexibility require a firm understanding of the total operation of the system for their correct operation. Please ensure that the following document is read in its entirety before making any attempt to operate the system.

Passwords

As the program in the system is critical to the correct operation during fire alarm conditions, it is protected from modification by a five-digit password. All other features are available without password protection.

Please ensure the password is recorded and stored in a safe place as it remains unique and your key to future system modification.

Operating Features

Alarm Verification selection per point, with tally.

Silence Inhibit timer and Auto Silence timer.

Automatic time-of-day and day-of-week controls functions, with holiday option.

User-defined password and key-protected nonvolatile memory.

AWACS (Advanced Warning Addressable Combustion Sensing) with nine field-adjustable Pre-Alarm levels with programmable Control-by-Event (CBE)

Operate automatic smoke or heat detector sounder base on action Pre-Alarm level, with general evacuation on alarm level.

Programmable Control-by-Event control of outputs from individual alarm addressable devices.

Basic System Requirements (SPECS)

The following section covers the suggested installation methods for the AFP-300/400. These are typical installation methods, and may not cover everything needed, Contact the Manufacturer for any additional information or assistance needed.

AFP-400 System Diagram

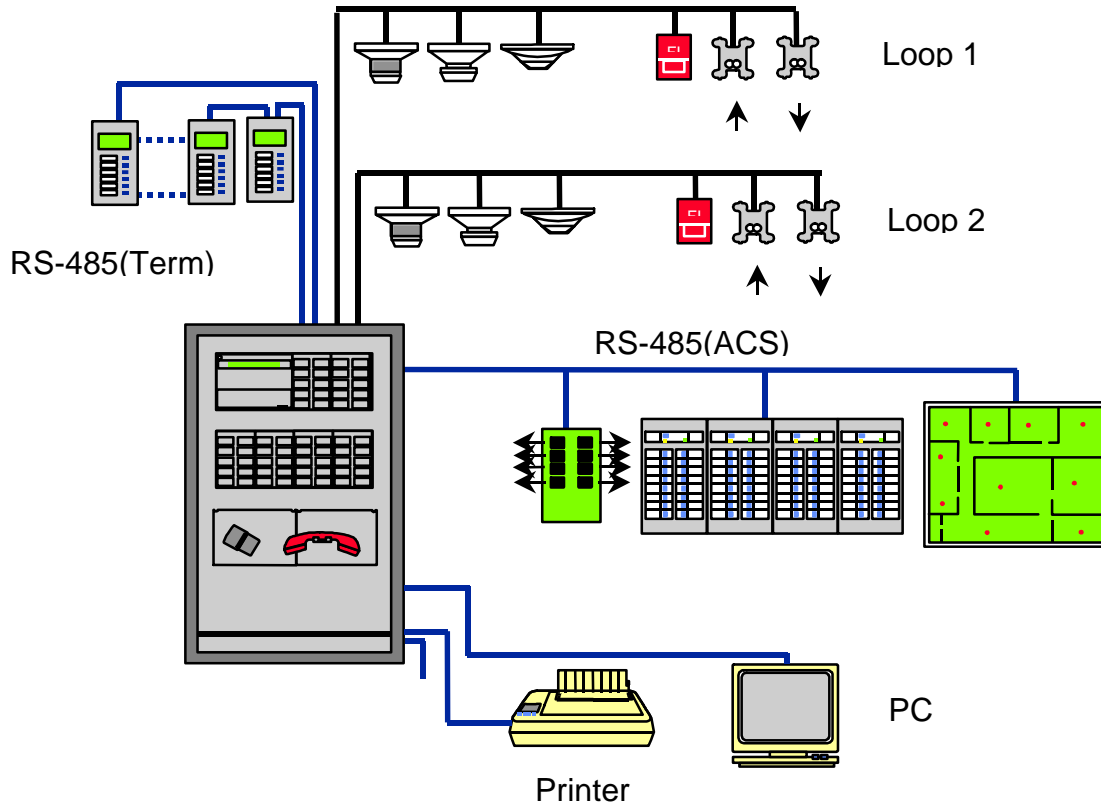

AFP-300/400 Basic termination points.

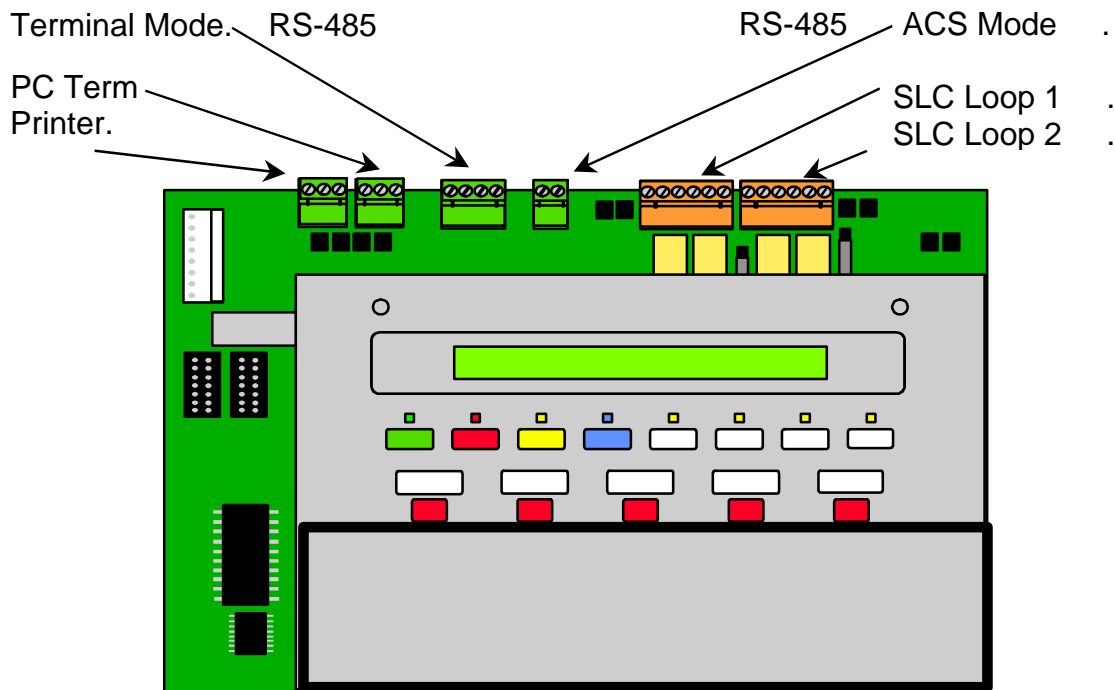

Panel Primary requirements

AC Power Requirements

Basic System 240VAC, 1.5A

Battery (sealed lead acid only)

Dual Rate Charger

High Charge 29.1VDC

Normal Rate 27.6VDC

Charging Current 2.0 A max, 1.5 A typical

Battery Capacity: 55AH in larger Cabinet, 12AH mounted in CAB-AA

24Vdc Power Supply:

Max. current for all external devices 6.0 A

(Optional power supplies available).

Communication SLC Loop

Voltage 24VDC nominal, 27.6VDC (supervised and power-limited)

Maximum Length 3,000 mtrs total twisted pair length, or
300 mtrs untwisted, unshielded wire pair.

Current 250 mA (max short circuit) or 100 mA normal

Resistance 40 ohms total (20 ohms per leg)

Monitored Outputs:

Max. wiring voltage drop 2 VDC

CMX-2: 1.2 VDC)

Normal Voltage 24 VDC

Clean Contact Relays:

2.0A @ 30VDC (Resistive)

0.5A @ 30 VAC Form-C

Compatible System Components:

Compatible Intelligent Addressable Devices include;

B501	Standard detector base
B501BH	Sounder base
B524RB	Relay base
B524BI	Isolator base
SDX-751	Photoelectric smoke detector low profile
CPX-751	Ionisation smoke detector low profile
FDX-551	Thermal Sensor
LPX-751	Very Intelligent Early Warning Laser Smoke Detector
IPX-751	Omni- Ion/Photo/Ther- Detector
DHX-501	Duct Detector housing for SDX-551 and CPX-551
DHX-502	Duct Detector housing for SDX-551 and CPX-551
MMX-2	Monitor module for two-wire detectors
MMX-101	Monitor module
CMX-2	Control module
ISO-X	Isolator module
XP5-C	5 way output card
XP5-M	5 way input card

Compatible Annunciators

- ACM-16AT** - Contains 16 red alarm and 16 yellow LEDs, and a local piezo sounder, Includes 16 switches for control panel functions.
- AEM-16AT** - Expands the ACM-16AT by 16 system points per unit, up to a maximum of 64 points per address.
- ACM-32A** - Contains 32 red alarm LEDs, and a local piezo sounder with silence/acknowledge switch.
- AEM-32A** - Expands the ACM-32A by 32 points
- ACM-8R-** Provides eight Clean contact (Form-C) relays with 5A contacts
- LDM-32-** Provides 32 Led driver outputs for connection to a custom graphic Mimic. Programmable for 32 alarm only outputs, or 16 alarm and 16 fault outputs.
- LDM-E32-** Expands the LDM-32 by 32 points up to a maximum of 64 points.
- LDM-R32-** Converts the open collector outputs of an LDM-32 or LDM-E32 to Form-A (normally open) contacts.
- LCD-80-** Alphanumeric display Mimic Panel

Initial Installation Tasks

Check AC Power –

- Apply AC power to the MPS-400, but do not connect batteries at this time.
- Silence the audible fault sounder by pushing the Acknowledge switch on the Keypad.

The Panel should indicate:

- The Green AC power LED on
- System Fault indicator because of no batteries
- The yellow fault indicator may come on after 10 seconds.

Program the AFP-400 (See Programming)

Connect the Batteries

Carry out common fault finding techniques (Page 19)

Test the System.

The Power Supply Connections

240Vac- 24Vdc (Resettable/Non resettable) and Battery Connections

The connections for the 240Vac and the 24Vdc Battery connections are indicated in the following illustration.

AFP-300/400 Power Supply

MPS-400 - Terminal TB2

Non-resettable power Terminal 1(+) & 2(-) Circuit 1

Non-resettable power Terminal 3(+) & 4(-) Circuit 2

Resettable power Terminal 5(+) & 6(-)

All DC power outputs are power-limited.

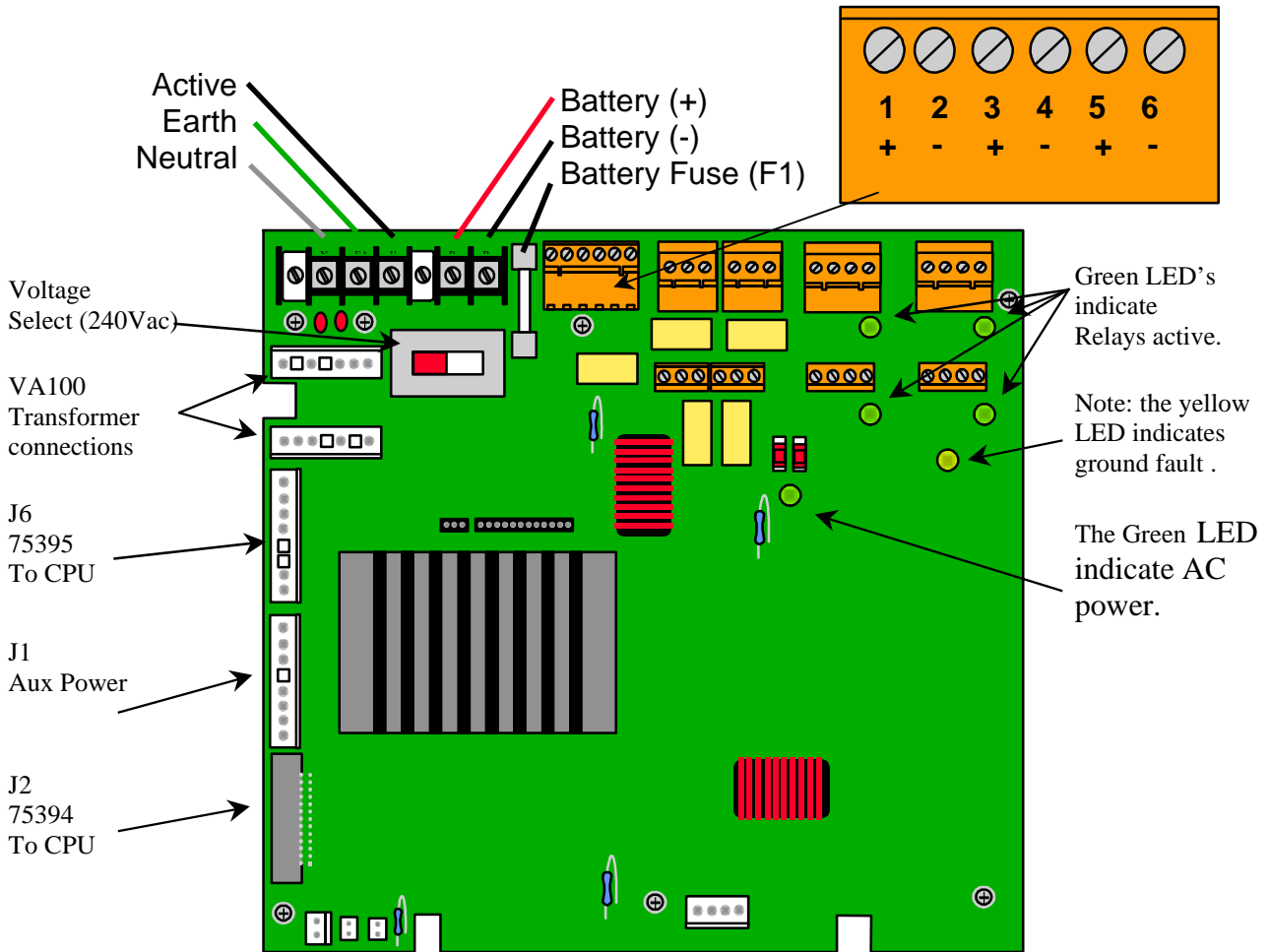

MPS-400 Battery Charger Supervision

The battery charger supervision circuitry uses the microprocessor and resistors R4 & R37 on the MPS-400, and resistors R123 & R124 on the CPU-400 to monitor the status of the batteries and the battery charger.

The microprocessor reads the battery voltage once every 15 seconds, and reads the battery charger voltage once every 4 seconds.

If the charger voltage rises above 31.5volts, the panel will report a "CHARGER FAIL" within 200 seconds. If the charger drops below 19.2volts, and the batteries are not fully charged <26.0V +/- 1%), the panel will report "CHARGER FAIL" within 200 seconds.

Output Relays (on the power Supply)

The control panel provides four monitored output circuits. Each circuit can Provide 2.5 amps of current. Total current drawn from the MPS-400 cannot exceed 6.0amps total.

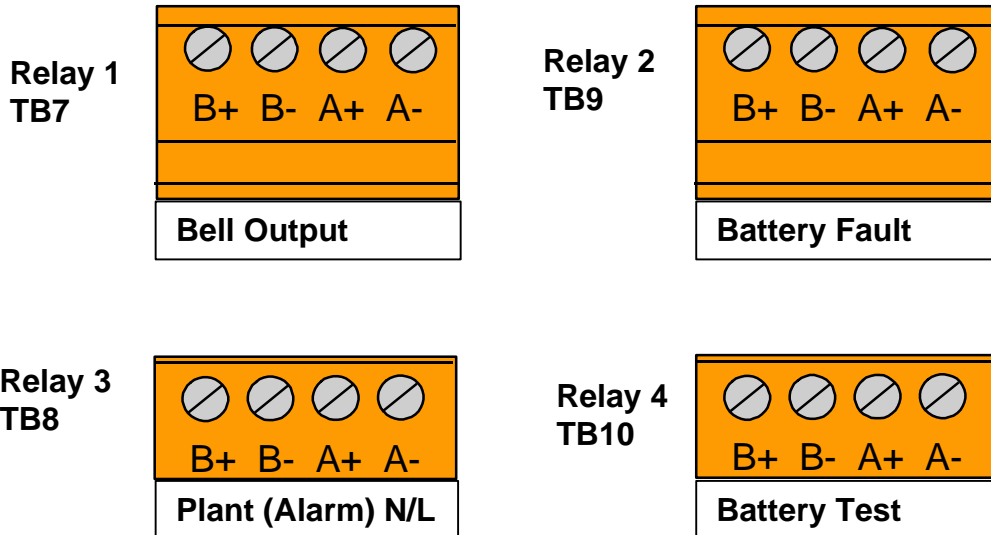

Alarm and Fault Relays (on the Power Supply)

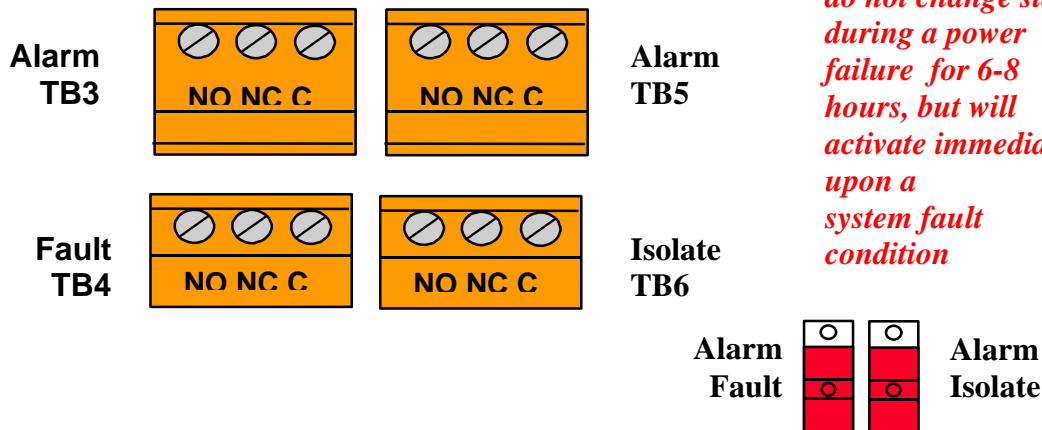

Isolate contacts can be set to Alarm activated contacts using SW4, Fault contacts can be set to Alarm activated contacts using SW5. 2.0A @30 VDC (resistive ratings).

RS-232 and RS-485 Circuits

The AFP-300/400 has multiple RS-232 and RS-485 circuits; the illustrations below show the positions and where to find them.

Wiring for RS-485 Annunciator Circuits

Terminal Mode (LCD-80/LCD-80TM) - The AFP-400 provides Terminal Mode for high-speed two-way communication link to multiple Annunciators. Maximum distance is up to 1,500 mtrs, and wired in twisted shielded cable.

Terminal Mode wiring must be Six wire, made up of, 4 wire For Data and 2 wire for 24Vdc power.

ACS Mode - Use the ACS Mode Interface for communicating with ACM-16AT, ACM-32A, LDM-32, ACM-8R modules. ACS mode can also ACKNOWLEDGE, SILENCE, and RESET the control panel from a remote location. Maximum distance is up to 1,500 mtrs, and wired in twisted shielded cable.

ACS mode wiring must be Four wire, made up of, 2 wire for Data and 2 wire for 24Vdc power. A 120-ohm resistor must be placed at the end of the cable run.

The AFP-400 uses ACS Annunciator address 1 to 19. Each address can communicate with one Receive/Transmit Annunciator. Configure any other Annunciators set for the same address as Receive Only.

The AFP-400 can support up to 32 Annunciators on the ACS output, all type combined. Each Annunciator Address (1-19) can be assigned to one Group Selection.

Note: Refer to the **ACS Selection tables** in the Programming section of this manual.

Terminal & ACS Circuits (RS-485)

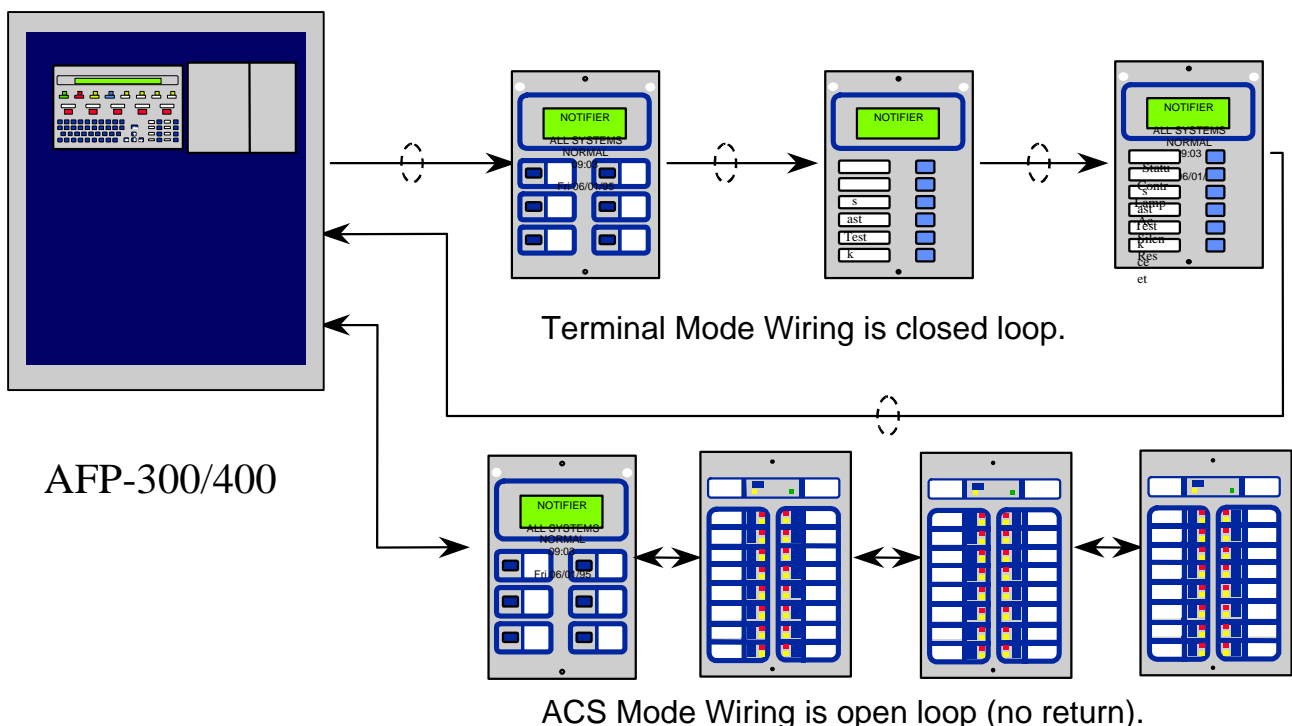

RS-485 Terminal & ACS Connectors

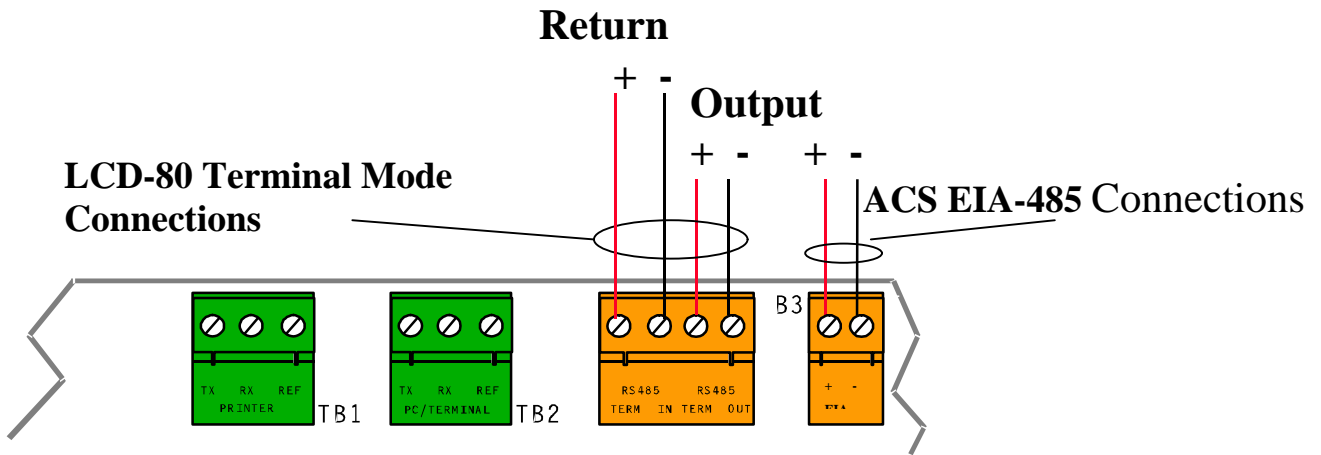

AFP400 to LCD-80 Terminal Mode Connections	
AFP 400 End (TB3 Terminal Mode Output)	LCD-80(TM) End (TB2)
RS 485 IN +	RS 485 OUT + (Terminal 1)
RS 485 IN -	RS 485 OUT - (Terminal 3)
RS 485 OUT +	RS 485 IN + (Terminal 2)
RS 485 OUT -	RS 485 IN - (Terminal 4)

Wiring for RS-232 Circuits

RS-232 circuits used for printer's etc, wired outside of the Panel, are to be wired in Twisted Shielded wiring and not to exceed 15 mtrs in length. The shield must be earthed at the Panel end, to the nearest earth point immediately inside the Panel.

The following illustrations indicate the connection points for RS-232 circuits.

Remote Printer Connections

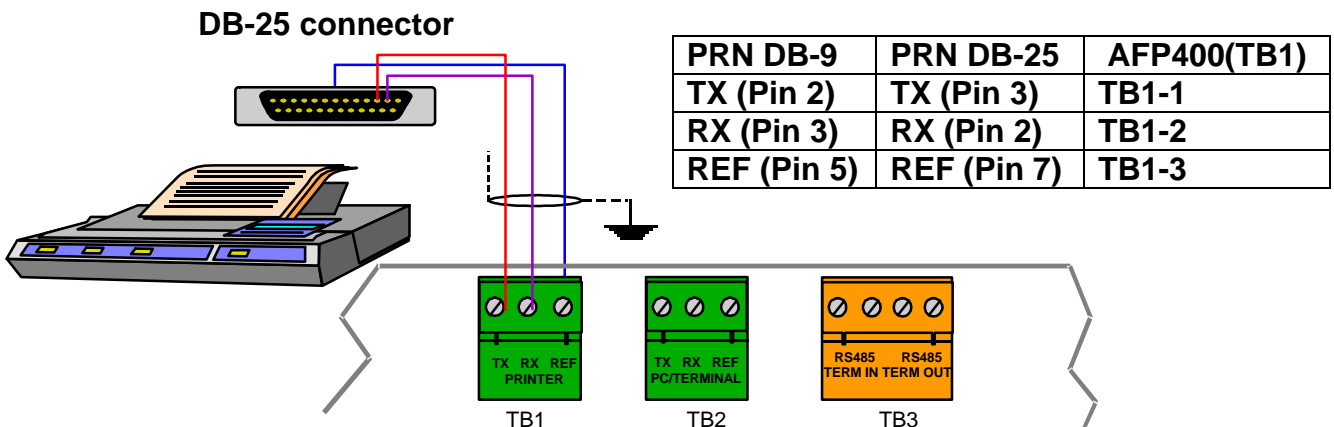

Remote Terminal Connections

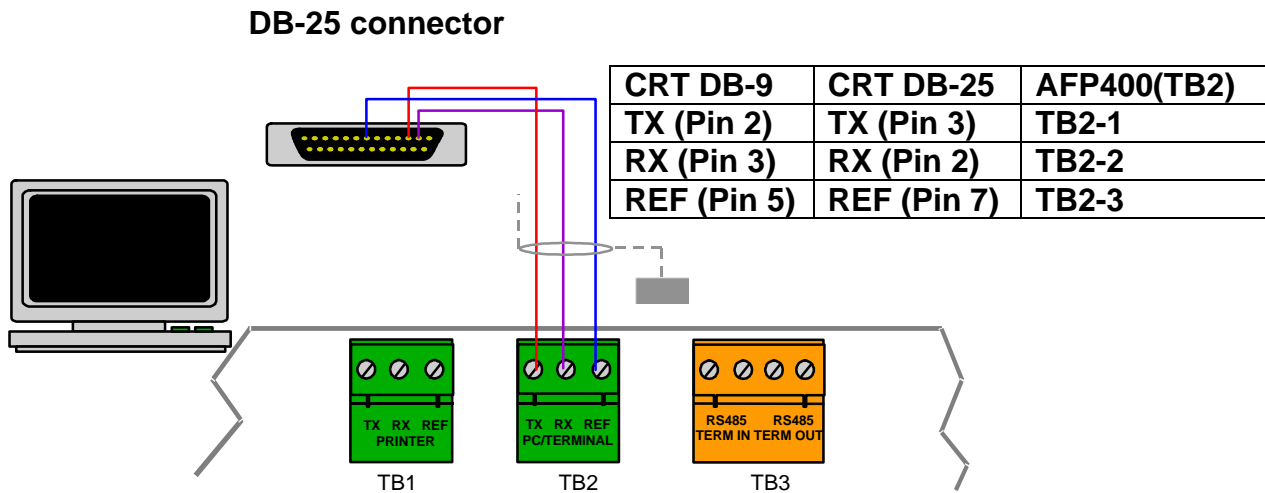

Connecting A Laptop in Terminal Mode to Emulate A Printer

A Laptop computer can be used in lieu of a printer for uploading the history file or capturing reports from the fire panel.

Set the Laptop up in terminal mode, and connect as per the instructions above for connecting a remote printer.

Place the Laptop in “terminal mode” (Hyperterm or equivalent) and set with the following options for the COM port.

- 2400 Baud.
- 7 Data bits.
- 1 Stop Bit.
- Even Parity.
- Xon/Xoff handshaking.

Select “Capture text to file” in the Terminal Mode program on the Laptop.

Then at the AFP-300/400 Panel Press <ENTER>-<2>-<3>-<ENTER>

The 300/400 panel will now Upload the entire history log to the Laptop computer which can then be saved to disk for permanent records.

Connecting a Laptop VIA Verifier 400 to program the Panel

Connect the Laptop to the Panel as per the instructions above for Remote Terminal Connections, using the cable provided with the Verifier 400 Upload/Download program, and follow the directions as per the Verifier Program.

Analogue Loop Overview

Communication with intelligent and Addressable devices occurs through a Signalling Line Circuit (SLC) Loop. You can wire an SLC loop in Style 4, Style 6 or Style 7 wiring.

The AFP-300 control panel capacity includes up to 99 intelligent detectors, and an additional combination of up to 99 Addressable modules, (control modules and monitor modules).

The AFP-400 control panel capacity includes up to 198 intelligent detectors, and an additional combination of up to 198 Addressable, control modules and monitor modules.

Loop wiring Methods and specification

The following section discusses the Loop specification in terms of size, distance, resistance etc;

Communication SLC Loop

Voltage	24VDC nominal, 27.6VDC (supervised and power-limited)
Maximum Length	3,000 mtrs total twisted pair length, or 300 mtrs untwisted unshielded wire pair.
Cable Size	Minimum .75mm ² Twisted pair.
Current	250 mA (max short circuit) or 100 mA normal
Resistance	40 ohms total (20 ohms per leg)

Style 4 Loop Wiring

Style 4: is when the circuit leaves the panel and does not return.

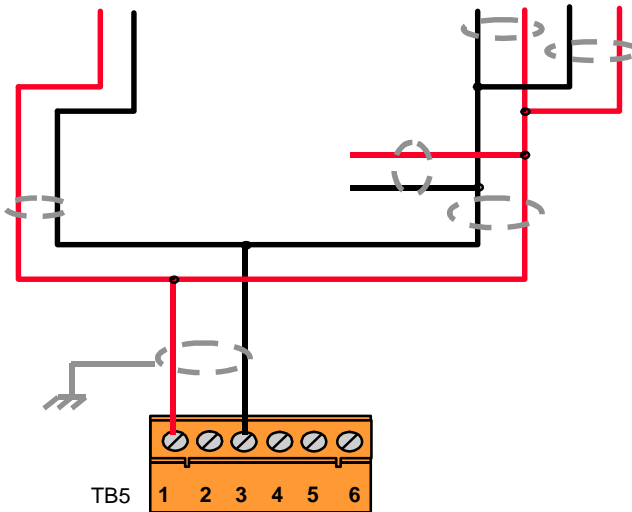

Total cable length must be $\leq 3,000$ mtrs.

Maximum impedance 40 ohms to the end of each branch

Wire size Minimum .75mm² twisted.

Style 6 Loop Wiring

Style 6 Wiring is a closed loop wiring method.

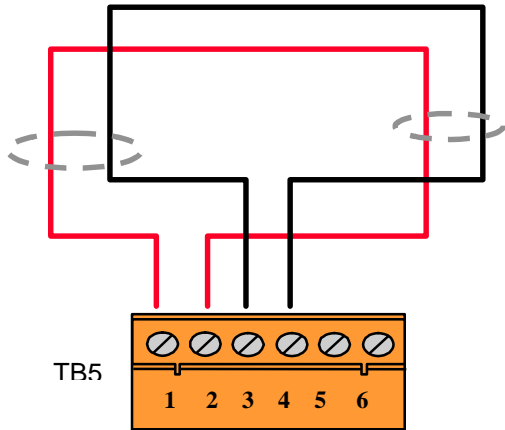

Total cable length must be $\leq 3,000$ mtrs.

Maximum impedance 20 ohms End to end of each wire (40 ohms total)

Wire size .75mm² twisted minimum

Style 7 Loop Wiring

Style 7 wiring is a closed loop wiring method with ISO-X's used for short circuit detection/ protection, without compromising the complete loop.

Maximum of 25 devices between each ISO-X device.

ISO-X's do not take up a device address, unless over 100 ISO-x's installed, then allow 2 addresses for each additional ISO-X device over 100.

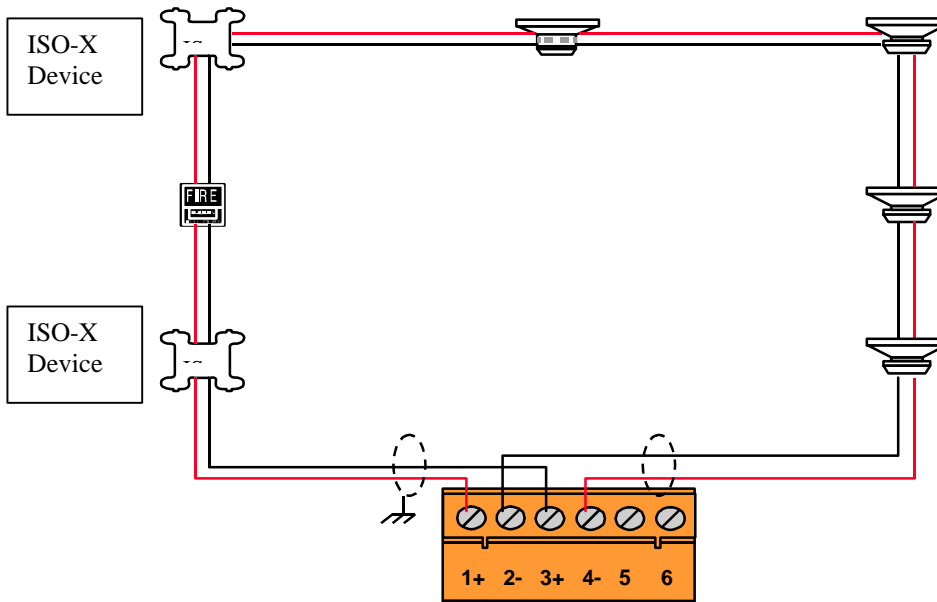

Wiring devices on the Loop

Please Note; Some of the wiring methods used in this manual only apply to the AFP-300/400, do not adopt these methods on other systems.

Wiring Analogue Addressable Detectors

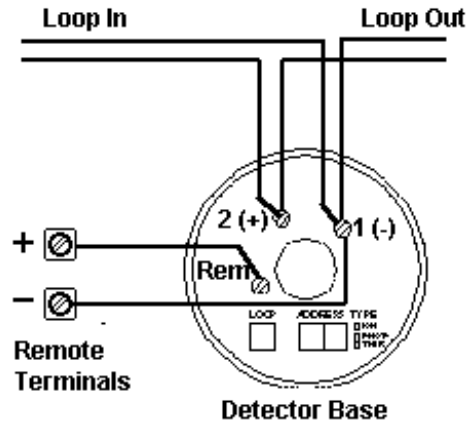

Note:

If optional shield used, do not connect to the spare terminal on the detector base, join the shield and insulate it from the other cables.

Wiring Conventional Circuits (MMX-2)

The MMX-2 utilises the 24Vdc Resettable power supply, and the Conventional circuit is terminated to terminal 6 & 7, with a 3.9k EOL Resistor fitted.

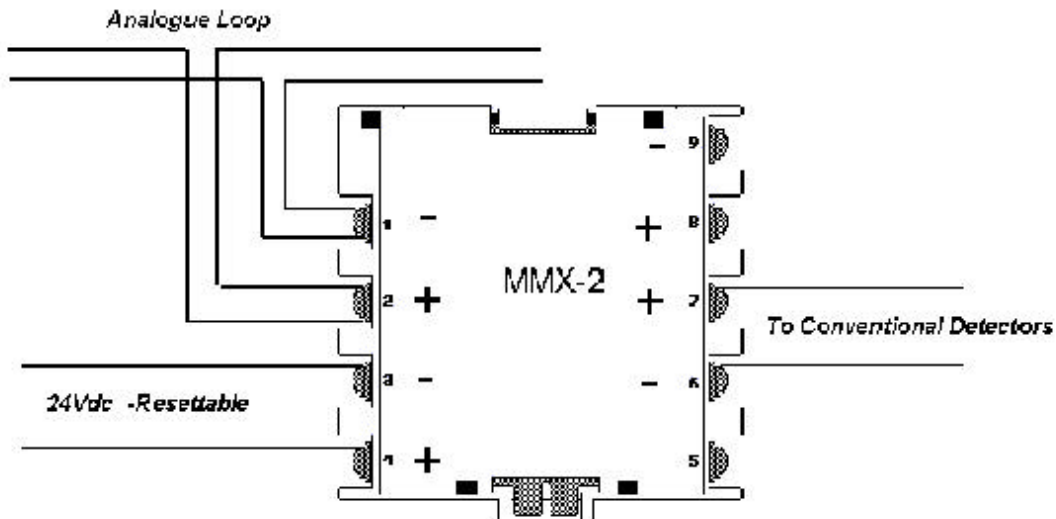

Note:

You must use resettable power on MMX-2's on an AFP400. You cannot have AVF on an MMX-2 Module.

Wiring Control Modules (CMX-2)

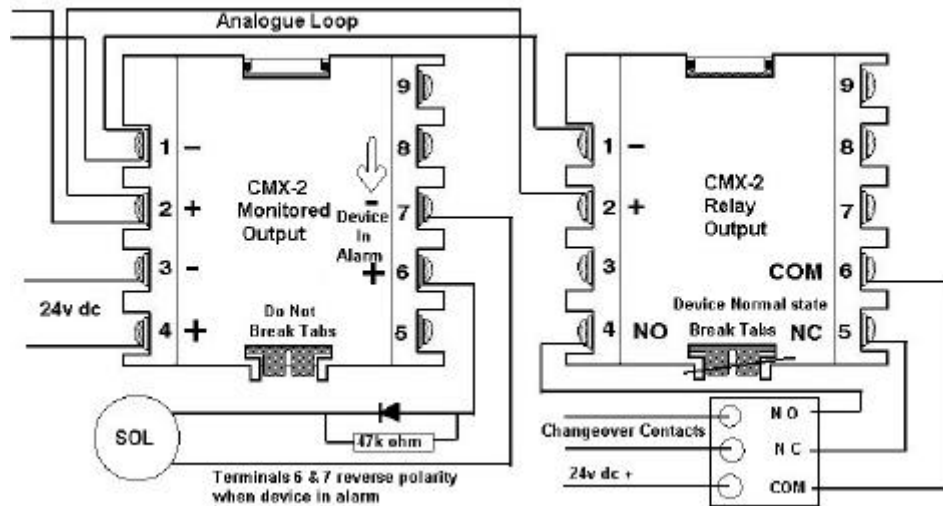

CMX-2's are used for Bells, Solenoids or any general relay application and can be monitored outputs or relay outputs.

Wiring Short Circuit Isolator Modules (ISO-X)

Note: When using the ISO-X module, limit the devices between each ISO-X to 25 devices.

In the case of "T" taping the limit of 25 also applies.

The ISO-X doesn't affect the device count unless the amount of ISO-x's exceeds 100

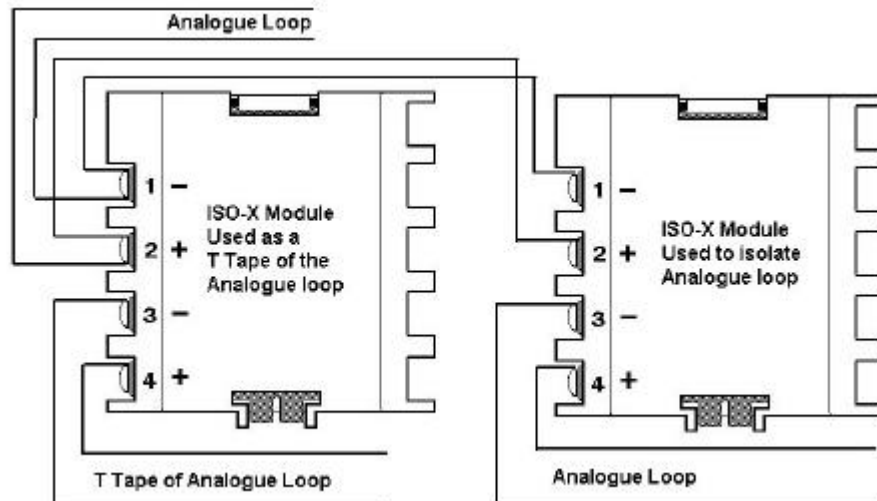

Shorts on the branch of an isolated communication loop are isolated from all devices installed before the ISO-X

Wiring Monitor Modules (MMX-101)

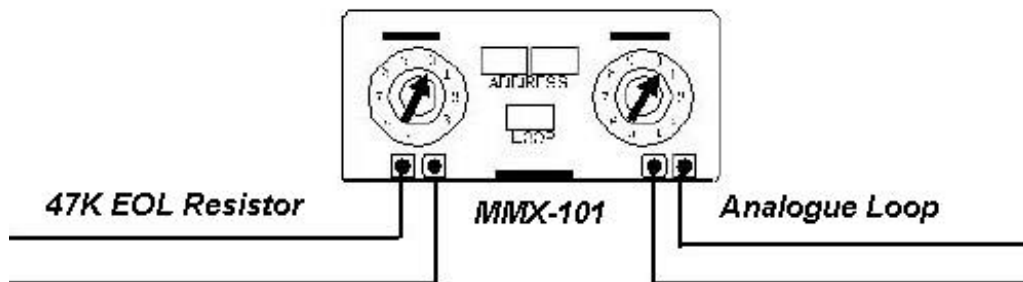

This Module is a single input device, and can be used for Flow switch, Tamper Switch, sprinkler pressure switch, and pump run/stop, and Tank Hi/Low monitoring. Maximum 700 mtrs distance and maximum 20 Ohms resistance.

XP-5M & XP-5C Modules

The XP-5 Control and XP-5 Monitor modules are 5 separate modules and addresses mounted on one circuit card, the address is chosen by one rotary switch and one slide switch. The rotary switch selects the address in increments of ten, and the slide switch selects either 0 or 5. Eg; address 52- the rotary switch will be 5, and the slide switch will be 0. Address 52 will be the third point on the XP-5 card.

The wiring of both the XP-5C and XP-5M are wired exactly as the CMX-2 and MMX-101 devices, the only difference being that they share the same loop connection.

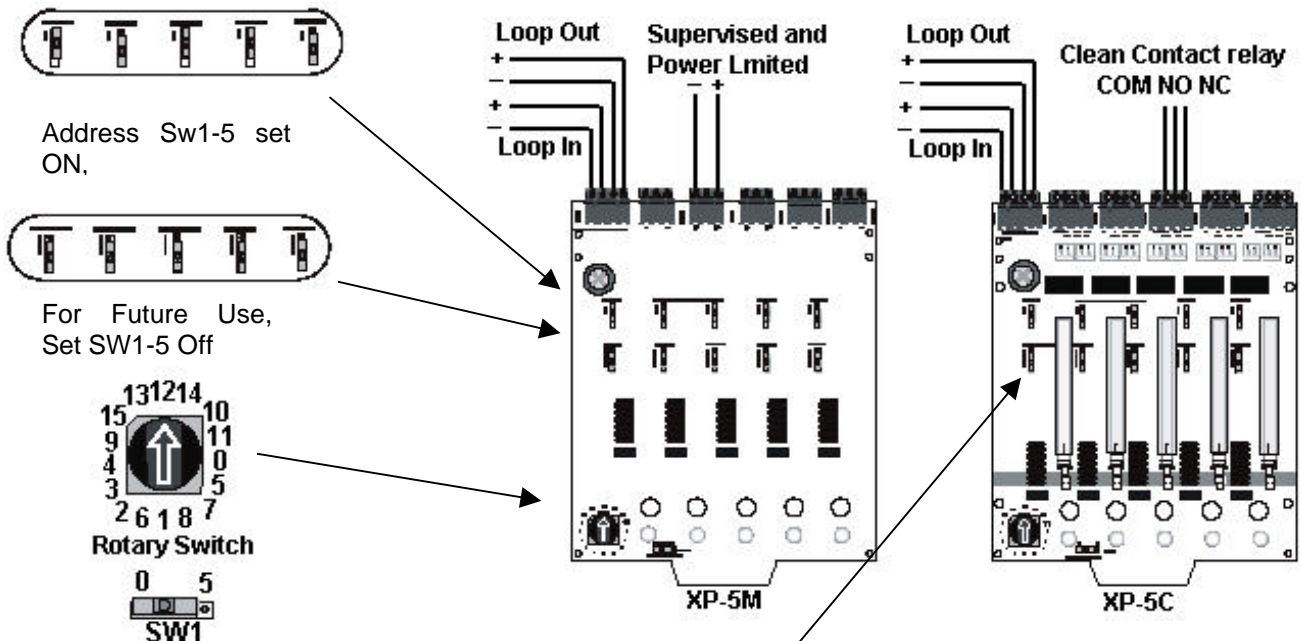

Note: Each output on the XP-5C is selectable via a switch.
Monitored output = Switch Depressed (Above Line)

Monitored output circuits are to be wired as per a CMX-2 and connected to the XP5-C as shown.

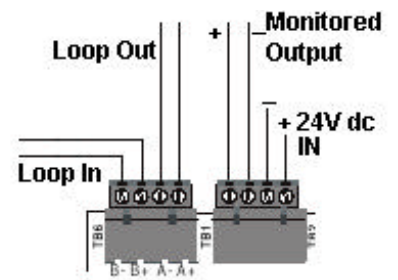

Common fault finding techniques

For a Loop that is wired in Twisted Shielded Pair:

Shield Termination

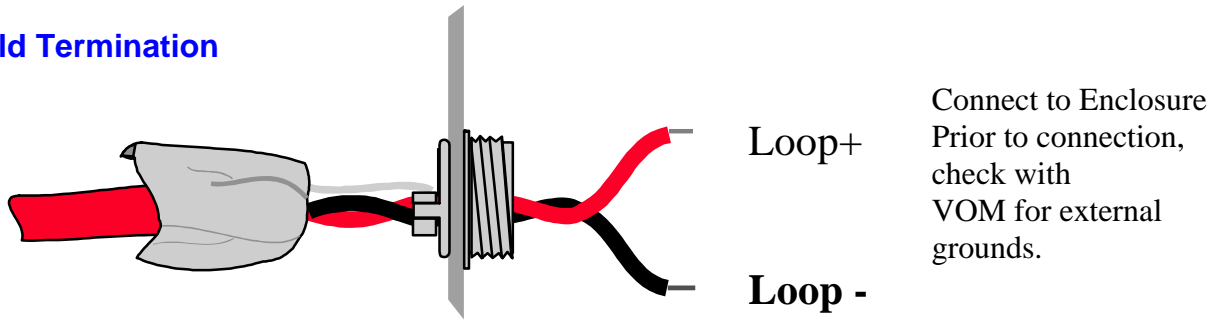

If Using optional shielded twisted pair cable to minimise radiated emissions of radio frequency energy, do not allow the shield drain wire to enter the cabinet. Connect the drain wire to the outside of the cabinet via an earth type connector. Maintain the continuity of the shield wire throughout the loop but do not connect to any devices, do not allow the shield to become grounded and only earth one end.

Before connecting the loop

Carry out the following tests;

1. Check continuity of loop wiring, by placing a short on one end and reading the short with a multimeter at the other end.
2. Check the loop resistance, same as above (be sure to set the multimeter to ohms), the loop resistance cannot exceed 40 ohms, which is 20 ohms per leg.
3. Check for devices incorrectly wired, set the multimeter to diode Test, and place the leads on the cable, the reading should be approx .645,- reverse the leads- now the reading should be approx 1.2 or higher, if both readings read low- this indicates a device incorrectly wired, or a short on the wiring.

Note: (Each device has a diode installed)

4. Voltage reading, set the multimeter to D.C. volts and read the voltage at the loop card before connecting the loop, the reading should be approx. 24 volts, now connect the loop, the reading should now be 15-16 volts. If the voltage goes down low this could indicate a short on the line, or there is a device incorrectly wired (possible Reverse polarity), find the device and correct the loop connections at that device.
5. Earth Fault test, Select ohms on the multimeter and check between each leg of the loop and earth, if the reading falls below 50,000 ohms, an earth fault will appear on the loop when connected, find the cause of the earth fault and rectify. (Possible causes of an earth fault are moisture, inadequate insulation from surrounding building, equipment or materials).

NOTE:

Loop Resistance Measurement when ISO-X devices are present and when power is removed from the Loop, the positive side of the circuit is opened at each ISO-X isolation module. To measure the Loop resistance, temporarily place a jumper between Terminals 2 and 4 on each ISO-X while taking measurements. Remember to remove all the jumpers and test all isolator modules when you have finished taking the readings.

The Affects of Capacitance on Ground Faults

Capacitance can be a major cause of induced ground faults. If the capacitance between the conductors and earth ground exceed a certain value, the capacitive reactance (X_c) will fall below the ground fault circuit threshold, and a ground fault condition will occur. When using shielded cable for the SLC loop wiring, it is important to realise that since a conductor is running in close proximity to the shield for a long distance, it is basically a large capacitor. If the capacitive value is known, the capacitive reactance can be calculated by using this formula:

$$X_c = \frac{1}{2\pi fC}$$

Where "F" is the frequency 0.5Hz, and "C" is the measured capacitive value in Microfarads. If the capacitive reactance is below 50,000 ohms, a ground fault will result.

Programming

Overview

The AFP-300/400 is 100% field programmable, and has the added versatility of the Autoprogram feature, the Panel can also be programmed using a Laptop Computer.

Turning the Panel on for the first Time

After system power up is completed, the display message will be:

Note: This would be for a new Unprogrammed AFP-300/AFP-400 panel

```
CHECKING MEMORY-AFP-400/300 Release 2.2
                        Australian 3.0
```

After system power up is completed, and memory test is performed, the display message will show:

```
FAULT IN SYSTEM      NO DEV. INST ON L1
                        09:40A MON 03/07/00
```

The programmer/installer can silence the internal Piezo sounder by pressing the Acknowledge switch on the Fire fighters Facility.

How to enter a 'Default' Program

Press the ENTER key to enter programming mode.

Technical Note: When programming mode is entered the ACS EIA-485 output is disabled.

```
1=PROGRAMMING 2=READ STATUS ENTRY
3=SYSTEM TEST      (ESCAPE TO ABORT)
```

Press <1> The system displays the following screen.

```
ENTER PASSWORD THEN ENTER, OR PRESS ENTER
FOR SYSTEM STAT CHANGE                <ESC>
```

Password Type Factory Default: **00000** Enter the programming password

When the password has been entered the screen gives you the following choices:

Program Mode Screen

**0=CLR 1=AUTO 2=POINT 3=PASSWD 4=MESSAGE
5=ZONES 6=SPL ZONES 7=SYS 8=CHECK PRG**

(This is the Program Mode Screen, referred to often in this section of the manual).

In program mode, the control panel:

- Activates the fault relay
- Shuts off the piezo
- Flashes the System Fault LED

To continue programming, select an option. To exit press backspace.

Clear Program

From the Program Mode screen, Press <0> (0=CLR) and this screen appears;

**PRESS ENTER TO CLEAR ENTIRE PROGRAM
OR ESCAPE TO ABORT**

Press the <Enter> Key to clear the entire program upon initial system startup.

Autoprogram

From the Program Mode screen, Press <1> (1=AUTO) and this screen appears;

AUTOPROGRAM PLEASE WAIT

Autoprogram identifies all installed devices, determines if new (un-programmed) devices are present, and presents any new devices to the user for editing and acceptance. It also loads default program information for new devices. When autoprogramming is first used, it also sets up default values for all system parameters.

An AFP-400 can be autoprogrammed with no devices connected to Loop #2, but there must be at least one device on Loop #1 or the system will display this fault message.

FAULT IN SYSTEM

**NO DEV. INST
ON L1**

If devices are installed and are programmed into the Panel, when the Autoprogram function is completed the screen will display the following;

```
L1:02 Dets, 02 Mods  L2:00 Dets, 00 Mods
Panel Outputs:  --  Bells:  04
```

L1:, L2: = the number of detectors and modules connected to each Loop
Panel outputs: -- (Not Used)
BELLS: = the number of panel bell circuits always equal to "04".

To accept the default autoprogrammed devices, press <ENTER>.

```
ACCEPT ALL DEVICES           Please Wait!
```

All Default values and devices are now set in memory.
Note: For double addressing see the following;

Duplicate (Dual) Addressing

When the <ENTER> key is pressed to load default values, the AFP-300/400 does not detect duplicate detector address's

If the programmer/installer wished to immediately check for duplicate detectors, carry out the following:

Select 1=AUTO a second time, after AUTOPROGAM is completed, and the <ENTER> key had been pressed, the display would indicate any Dual Detector Address's

Please Note: for this particular function Do not clear the program.

If a dual address is found, the screen will show the following:

```
Dual      Address      at      Detector      D102
```

Press <ENTER> to accept the Function.
Then proceed to rectify the dual address.

After rectifying the Dual address, go back to the Autoprogram mode, and carry out another Autoprogram to find the device.

In Program Mode select 1=Auto. the screen will then come back with the device that was last installed or address had changed. As the next screen shows:

Default Autoprogram Screen

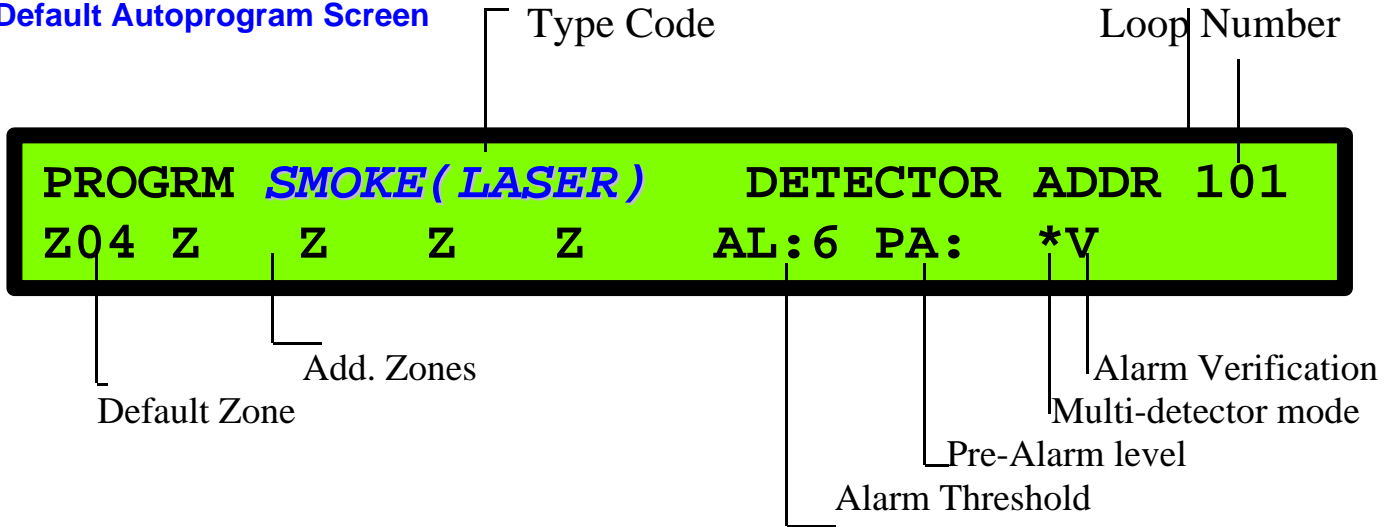

The programmer can now begin editing the default values: and then Press <ENTER> to accept.
 Note: The following table explains the default values.

Autoprogram Defaults

Field	Description
SMOKE(PHOTO)	Type code for device
DETECTOR ADDR 101	Default custom label
Z03	Default Zone selection
	Zone 01 (heat detectors)
	Zone 02 (Ion detectors)
	Zone 03 (Photo Detectors)
	Zone 04(Laser Detectors)
	Zone 05(Multi-Detectors)
AL:	The alarm sensitivity level, with "9" the least sensitive, and "1" the most sensitive.
PA:	The Pre-Alarm Sensitivity level, with "9" the least sensitive, and "1" the most sensitive
*	Multi detector mode, "A" indicating detector after, "B" indicating detector before, and "C" indicating detector before and after.
V	Alarm Verification

Autoprogram- Device no longer needed

If a detector exists in the control panel program, but is missing (no response from the device), the control panel will display the following:

```

PROGRAM SMOKE (PHOTO)      DETECTOR ADDR 133
DEVICE NOT ANSWERING DELETE FR MEM? D133
  
```

To delete the device, press <ENTER>

To keep the device, press <ESC>

Installing a Device

Address the device to a spare address and connect to the loop, then carry out an Autoprogram function to find the device. Modify the default values to suit. **See Autoprogram Section above.**

Edit a Point

Select 2=POINT. From the Program Mode screen.

You can now modify or delete a point. To modify a point for a detector, module, or output circuit, press <1> to display the Modify Point screen, or press <2> to display the Delete Point screen.

PLEASE NOTE:

For information on Type Code's please see the section **Type Code (ID's)**

```

POINT PROG.      1=MODIFY POINT
2=DELETE POINT
  
```

Modifying a Point

Press <1> to modify a point the screen will now show:

```

POINT PROG. ENTER:  DETECTOR=* , AAA . E
MODULE=# , AAA , E
  
```

Press the Detector key, then enter the address of the detector you wish to edit, and press <ENTER> :Once a Device is selected the screen will now show:

```

PROGRAM SMOKE (LASER)      DETECTOR ADDR 101
Z04 Z   Z   Z   Z   AL:6 PA:  *V   D101
  
```

You can now change the Type Code, the detectors description, the Zones mapped to that detector, the alarm level, the pre-alarm level, the multi-mode function and the Verification.

PLEASE NOTE:

For information on Type Code's please see the section **Type Code (ID's)**

* *multi detector mode described next.*

Editing Multi Detector Mode

Multi detector mode Uses Adjacent Addresses

Select Address above or below or both (both shown below). The chamber values are added, and when the total reaches 100% an alarm condition is displayed. The chamber with the highest reading will be the alarm point.

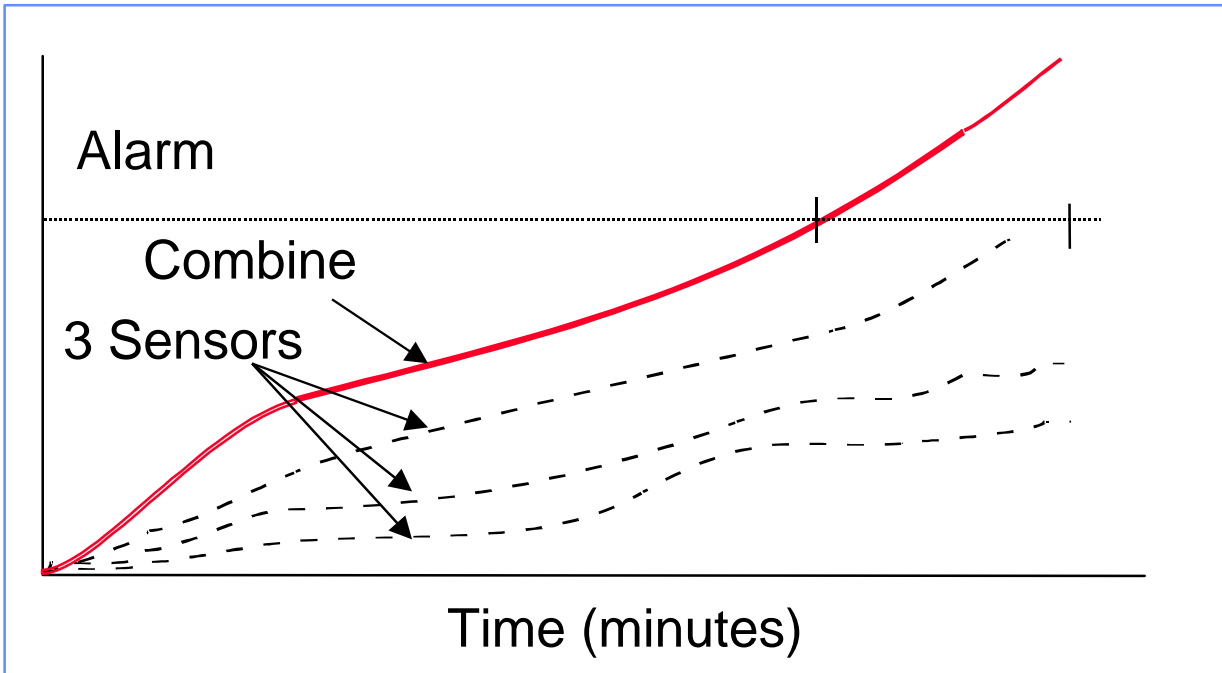

Programming Cooperative Multi-Detector

Use the following table to select the desired application:

Selection	Meaning
* (none)	This detector will not consider other detectors in its alarm or pre-alarm decision
A (above)	This detector will consider the detector one-address number higher in making its decision.
B (below)	This detector will consider the detector that is one address number lower in making its decision.
C (centre)	This detector will consider the detector address above and below in making its decision

Delete a Point

At the Edit point screen select 2=DELETE POINT, the screen now asks you to choose which point you want to delete.

Example: Press Detector then the address <1>-<0>-<1>-<ENTER> the screen now asks:



Pressing <ENTER> will delete the device, the screen will then allow you to select another one to delete, or press <ESC> to abort.

Password

Password change lets you customise the system password. From the program mode screen, press <3> to display the Change Password Screen:



Change the Program Password by Typing in the new program Password



After pressing <ENTER> the screen will now show:

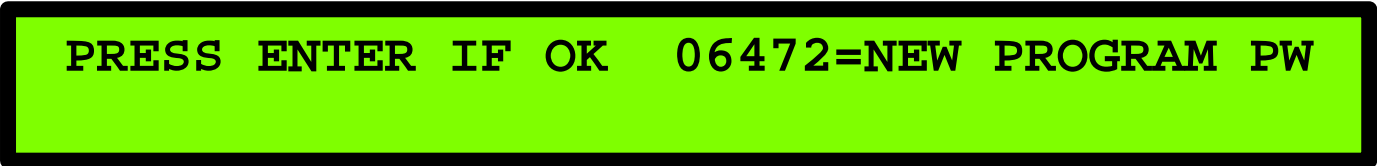

Press <ENTER> to accept the new password.

Message - Change the "SYSTEM NORMAL MESSAGE"

Selection 4 = MESSAGE from the Program Mode Screen allows you to change the 40-character "All Systems Normal" message. From the program Mode Screen, press <4>, the control panel will display the Message Change Screen:



Change one character at a time, indicated by the blinking cursor on the Display, Enter up to 40 characters maximum.

Enter lower case and special characters by pressing and holding the <Lower Case> key then typing the character.

Zone Labels

The Zone option lets you change the custom label assigned to zones 1-99. From the Program Mode Screen, select <5> to display the Zone Change Screen.



The zone number displays on the first line
 For single digit numbers, enter a leading zero before the digit
 Enter an alphanumeric zone label into line 2
 The program forces a blank for the first character, which inserts a space between the device and zone labels for a printout.

Special Zones

The Special Zone Change option lets you change the program for special zones F0-F9 or releasing Zones R0-R9. From the program Mode change screen, select <6> to display the Special Zone Change Screen:



The following table explains the Special Functions:

Special Functions	Lets You
F0 (Presignal)	Not supported in AUS 3
F1	Not supported in AUS 3
F2	Not supported in AUS 3
F3	Not supported in AUS 3
F4	Not supported in AUS 3
R0-R9 (Releasing)	Not supported in AUS 3
F5-F6 (Time Control)	Change the start time, stop time, or days of the week.
F7 (Holiday)	Select up to nine holiday dates. Any device programmed to F7 activates on the specified holiday dates.
F8	Not supported in AUS 3
F9	Not supported in AUS 3

F5-F6 (TIME CONTROL)

```

PRG   TIME   FUNCTIONS           TIME CONTROL
ON =  **:**   OFF =  **:**   DATES =  *****)

```

Selecting F5-F6 screen provides field for changing the start time, stop time, or days of the week. From Special Zone Change screens, select F5 or F6 to display the Time Control screens..

```

PRG   TIME   FUNCTIONS           TIME CONTROL
ON =  08:00   OFF =  18:00   DATES =  *MTWTF*H

```

Example of a time control program, which would cause an output to be activated Monday through Friday, except on holidays. (Zone F07 must also be programmed for the specific holidays). The output must also be assigned to Zone F05/F06, depending upon the zone programmed

F7 (Holiday)

```

PRG HOLIDAY FUNC           **/**  **/**  **/**
**/**  **/**  **/**  **/**  **/**  **/**  F7

```

Selecting F7 allows the programmer to enter the day and month for holiday control.

System Functions

The System option lets you set general system functions. From the program mode screen, select <7> to display the System Functions screen:

```
SIL INH=000  AUTO=000  VERIFY=30  AUS TIME
TERM_SUPERV=NO  LocT  BLINK=Y  ST=4  ACS=N
```

System Function	Setting	Default
SIL INH	0 to 300 seconds	0
AUTO	0 = none, 600 to 900 seconds	0
VERIFY	0 to 30 seconds	0
AUS TIME	USA TIME (with Next/Previous keys).	AUS TIME
	European time format changes to 24-hour time, and places the day before the month	
TERM_SUPERV	NO or YES	NO
Loc T	Loc M (Local-Terminal Mode) Rem T (Remote Terminal Status)	Loc T
BLINK=Y	Set to Blink=N (no blink)	Blink=Y
ST=4	ST=6 (Style 6 wiring)	ST=4
ACS	N or Y	ACS=N

ACS =N (Annunciators are discussed in the next section).

Annunciator selection

Selecting ACS=Y will display the Annunciator Selection Screen

```
ANNUN SELECTION  A1=*    A2=*    A3=*    A4=*
A5=*  A6=*  A7=*  A8=*  A9=*  A10=*    UDACT=N
```

Use the Annunciator Selection screen to select the information that will display on the ACS annunciators. The following table contains the ACS display selections: Each annunciator can be assigned to any group functions, or all annunciators can be assigned to the same group.

Example: in the Annunciator Selection screen select A1=* and press <1> This now selects Annunciator Group 1 as your choice for Annunciator 1.

Annunciator Groups

ACS Selection	Annunciator Display
Group 1	CPU Status + Zones 1-56
Group 2	Zones 57 to 99, Ind Ckts 1-4 & 16 Spec Zones
Group 3	Intelligent Modules 101 to 164
Group 4	Intelligent Modules 201 to 264
Group 5	Intelligent Modules 165 to 196 & 265 to 296
Group 6	Detectors 101 to 164
Group 7	Detectors 201 to 264
Group 8	Detectors 165 to 196 & 265 to 296
Group 9	Not used in Australia
Group 0	Annunciator not installed at address
*	Annunciator not installed at address

Annunciator Group 1

ACS Point Number	Point Type	Red LED	Yellow LED	Switch
1	Input	System Alarm	System Fault	Acknowledge
2	Output	not used	Signal Silenced	Signal Silence
3	Output	not used	Program Mode	System Reset
4	Output	Not used	Supervisory	Drill
5	Output	NAC#1 Active	NAC Fault	NAC#1 Control
6	Input	not used	PA/Maint. Alert	Not used
7	Input	not used	Low Battery	Not used
8	Input	not used	AC Fail	Not used
9 to 64	Input	Zone 1 to Zone 56 alarm	Zone 1 to Zone 56 Fault	Not used

Annunciator Group 2

ACS Point Number	Point Type	Red LED	Yellow LED	Switch
1 to 43	Input	Zone 57 to 99 Active	Zone 57 to 99 Fault	Not used
44 to 52	Output	Zones F1 to F9 Active	Zones F1 to F9 Fault	Not used
53 to 60	Output	Zones R0 to R7 Active	Zones R0 to R7 Fault	Not used
61	Output	NAC 1 Active	NAC 1 Fault	NAC 1 Control
62	Output	NAC 2 Active	NAC 2 Fault	NAC 2 Control
63	Output	NAC 3 Active	NAC 3 Fault	NAC 3 Control
64	Output	NAC 4 Active	NAC 4 Fault	NAC 4 Control

Annunciator Group 3-5

ACS Point Number	Point Type	Red LED	Yellow LED	Switch
Group 3 1 to 64	Input or Output	Modules 101 to 164 Active	Modules 101 to 164 Fault	Control Module Operation
Group 4 1 to 64 AFP-400	Input or Output Only	Modules 201 to 264 Active	Modules 201 to 264 Fault	Control Module Operation
Group 5 1 to 32	Input or Output	Modules 165 to 196 Active	Modules 165 to 196 Fault	Control Module Operation
Group 5 33 to 64 AFP-400	Input or Output Only	Modules 265 to 296 Active	Modules 265 to 296 Fault	Control Module Operation

Annunciator Group 6 – 8

ACS Point Number	Point Type	Red LED	Yellow LED	Switch
Group 6 1 to 64	Input	Detectors 101 to 164 Alarm	Detectors 101 to 164 Fault	Not used
Group 7 1 to 64 AFP-400	Input Only	Detectors 201 to 264 Alarm	Detectors 201 to 264 Fault	Not used
Group 8 1 to 32	Input	Detectors 165 to 196 Alarm	Detectors 165 to 196 Fault	Not used
Group 8 33 to 64 AFP-400	Input Only	Detectors 265 to 296 Alarm	Detectors 265 to 296 Fault	Not used

System Check Function

When finished programming use the Check option to search the program entries for possible errors. From the program mode screen, select <8> to check the system program, the screen will now show:

```

PRORAM CHECK OK.
RE-TEST PANEL NOW      11:10A  Wed  05/07/00
  
```

When Check completed the screen will show possible errors in the program:

Output points mapped to a zone without a mapped input

A zone with mapped inputs without mapped outputs

Releasing Zone Inputs (R0-R9) with no RELEASE CKT outputs mapped to them.

R0-R9 Inputs not mapped to MAN RELEASE.

If the Check options detects errors, return to Point Programming and correct the errors.

Status Change

Press the <ENTER> key to enter programming mode.

Technical Note: When programming mode is entered the ACS EIA-485 output is disabled.

```

1=PROGRAMMING 2=READ STATUS ENTRY
(ESCAPE TO ABORT)
  
```

Press <1> The system displays the following screen.

```

ENTER PASSWORD THEN ENTER, OR PRESS ENTER
FOR SYSTEM STAT CHANGE                <ESC>
  
```

Press <ENTER> The screen now display's:

```

STATUS CHANGE PRESS: 1=ISOL/DEIS  2=SENSITIV
3=CLR VER  4=CLR HIST  5=TIME  6=WALK TEST
  
```

The Status change screen allows you to change control panel operating parameters. These operating parameters do not affect the basic configuration or the control program settings. The control panel will return to standard mode whenever the keypad is inactive for more than 2 minutes.

Isolate a Device or Zone

Select <1> from the Status Change screen to display the ISO/DE-ISO Screen

```
ZONE=Z , AA , E      DETECTOR=* , AAA , E
MODULE=# , AAA , E
```

Enter the address of the point, then press <ENTER>. Example:- Select the point type: * for detectors Then Press <1>-<0>-<1>-<ENTER> A sample display is:

```
ISOLATE SMOKE ( PHOTO )      DETECTOR ADDR 101
Z01  Z02  Z03  Z04  Z05      AL:5
```

You can Isolate or De-isolate a point by pressing the next button this will change the 'Blinking status banner'.

Please Note; The same can be done for Modules and Zones.

Change Sensitivity

Select <2> from the Status Change screen to display the Detector Sensitivity screen.

```
DET. SENS & COMP.      ENTER POINTS:AAA,E
```

Enter the address of an installed detector and the control panel displays the following screen:

```
PROGRM SMOKE ( PHOTO )      DETECTOR ADDR 101
Z03 Z04  Z05  Z06  Z85      AL:5 PA:7
```

The values for Alarm Level are 1-9, 1 most sensitive

The values for Pre-Alarm are 0-9, 1 most sensitive, 0 no pre-alarm.

Note: For nominal Sensitivity levels after an Autoprogram see Pages 39-41.

Or to automatically change Sensitivity levels at a given time see 'Automatically Change sensitivity' on page 38

Clear Verification Counters

Select <3> from the Status Change screen to clear all verification tally counters for detectors selected for alarm verifications.

```
PRESS ENTER TO CLEAR VERIFICATION COUNTS
OR ESCAPE TO ABORT
```

Pressing <ENTER> will clear the all verification counters

Pressing <ESC> to return to the Status Change screen without clearing.

Clear History

Select <4> from the Status Change screen to display the Clear History screen:

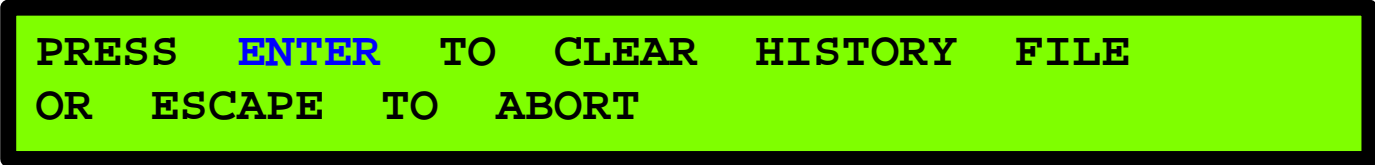

Pressing <ENTER> will clear the contents of the history file and return to the Status Change screen, or Pressing <ESC> to return to the Status Change screen without clearing.

Time and Date

Select <5> from the Status Change screen to display the Time/Date screen:

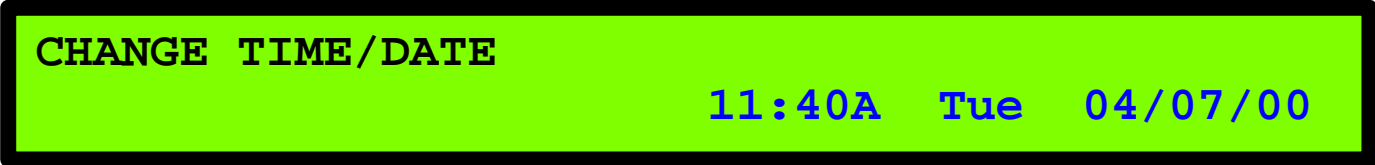

The first digit flashes until the change the value, or press <ENTER>. To change the time and date values, input the values from the numeric keys on the keypad

Walk Test

The Walk Test option <6> from the Status Change screen lets you test the ENTIRE fire alarm system (both loops) while away from the control panel. You can select one of two ways to do the Walk Test.

Standard Walk Test, CBE activated alarms sound for 3 seconds

Silent Walk Test, active alarms do not sound

Note:

1/ The AFP400 provides a 1-hours timer for Walk Test mode. When the timer expires, the AFP400 returns to standard operation.

2/ When testing a detector the LED will flash on/off rapidly, but will latch on (steady) during a Alarm activation. Please allow several seconds for alarm activation.

3/ Before Selecting Walk Test

Faults- all control modules in the CBE programmed for Walk Test, activate for a longer period (about 8 seconds). The control panel sends the Fault banner "TEST Txx" to the history file and printer.

Silent Walk Test - do not select any of the output modules for Walk Test (W) when programming the system.

Select <6> from the Status Change screen to display the Walk Test screen:

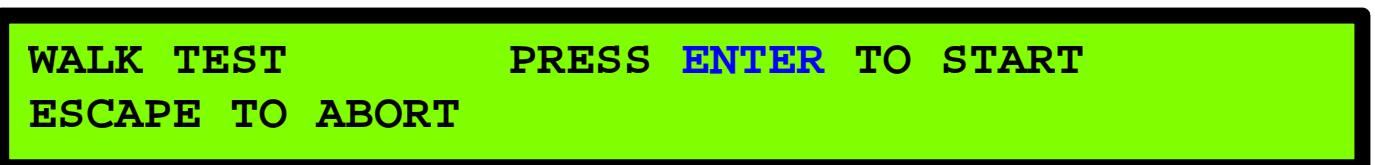

To began Walk Test, press <ENTER>.

To stop a Walk Test and return to the Status Change screen press <ESC>.

All Walk Test results go straight to the History Log.

Type Codes (ID's)

Please Note: when installing detectors the panel will determine the Type code for that detector, when installing modules, the panel gives a default Type Code, and then the programmer can determine what Type Code suits the application. The following section shows a table of the different Type Codes used for Monitor modules and Control Modules.

Monitor Module's

To install a point see Autoprogram, . To modify a point, See Edit point.

```

PROGRM MONITOR      MODULE ADDR 101
Z04 Z    Z    Z    Z      M101
    
```

Use the Next and Previous keys to select a code type from the selection list.
 Use the arrow and alphanumeric keys to modify the point.
 When finished, press <ENTER>, and use the Next or Previous keys to select another point to modify.

Type Codes for Monitor Modules

Type Code Label	Function
MONITOR	(default for MMX-101 & MMX-2) Any alarm module should be given a MONITOR type ID.
PULL STATION	*Not supported in AUS 3
SMOKE DETECT	*Not supported in AUS 3
HEAT DETECT	*Not supported in AUS 3
Blank (12 spaces)	*Not supported in AUS 3
WATERFLOW	*Not supported in AUS 3
SUPERVISORY	*Not supported in AUS 3
TAMPER	*Not supported in AUS 3
NON FIRE	*Not supported in AUS 3
HAZARD ALERT	*Not supported in AUS 3
FIRE CONTROL	*Not supported in AUS 3
ABORT SWITCH	*Not supported in AUS 3
MAN. RELEASE	*Not supported in AUS 3
SILENCE	*Not supported in AUS 3
SYSTEM RESET	*Not supported in AUS 3
EVACUATE	*Not supported in AUS 3
PAS INHIBIT	*Not supported in AUS 3
TROUBL MONITOR	*Not supported in AUS 3
FAULT MONTOR	*Not supported in AUS 3
MAN REL DLAY	*Not supported in AUS 3
SECOND SHOT	*Not supported in AUS 3
SPRINKLR SYS	*Not supported in AUS 3
COMB. MONITOR	*Not supported in AUS 3

***Important Note:** The Type ID that are not supported by AUS 3 are still available in verifier but should not be used for programming purposes as they can cause system failures.

Control Module's

To install a point see Autoprogram, To modify a point, See Edit point. Programming control modules or panel outputs is similar to Monitor Modules except the default zone is always set to Zone 00 (General Alarm).

```

PROGRM Relay          MODULE ADDR 108
Z00 Z  Z  Z  Z  IS *      M108
    
```

Type Codes for Control Modules

Type Code	Special Function
CONTROL	*Not supported in AUS 3
RELAY	Ignore Open Circuit Relay Output
STROBE CKT	*Not supported in AUS 3
BELL CIRCUIT	Supervised NAC
HORN CIRCUIT	*Not supported in AUS 3
AUDIBLE CKT	*Not supported in AUS 3
REL END BELL	*Not supported in AUS 3
Blank label	*Not supported in AUS 3
RELEASE CKT	*Not supported in AUS 3
REL Ckt ULC	*Not supported in AUS 3
RELEA. FORM C	*Not supported in AUS 3
REL AUDIBLE	*Not supported in AUS 3
NON RESET CTL	*Not supported in AUS 3

***Important Note:** The Type IDs that are not supported by AUS 3 are still available in verifier but should not be used for programming purposes as they can cause system failures.

Panel's Monitored Output Circuits

Default zone is always set to Zone 00 (General Alarm).

```

Type Code
PROGRM BELL          PANEL CIRCUIT 1
Z00          IS *      B01
    
```

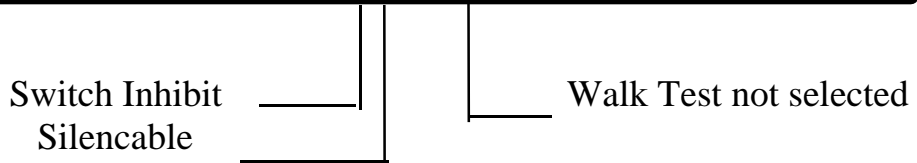

The 4 panel relays B1-B4, are fixed in core software and are not programmable except for the following default parameters for the above programming screen:

- * Switch Inhibit (I) Annunciators in the module's range cannot activate;
- * Silenceable (S);
- * Walk Test (*) not selected

Control-By-Event Programming

CBE Equation

Each input can be assigned up to five different software zones (1-99 or SPL Zones). All inputs are also assigned to Z00 (General Alarm Bus), which insure that any Fire Alarm Device will activate a Fire Alarm condition. Note that all inputs have default zone assignments.

Each output can be assigned from one to five different software zones (1-99 or SPL Zones). A zone can have no input/output assigned, or unlimited inputs/outputs may be assigned to one zone. Note that zone status is also transmitted on the EIA-485 circuits to ACS Group 1, P9-P64

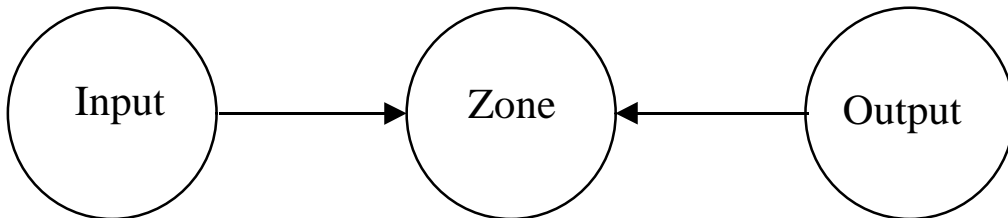

Automatically Change sensitivity

Each input can be assigned up to five different zones, including special zones. If the programmer wanted the CPU-400 to automatically adjust a detector sensitivity to the lowest selection (9) during a specific time period/day, he would assign that detector to Zone F05/F06, and define the time or day period in Zone F05/F06 programming.

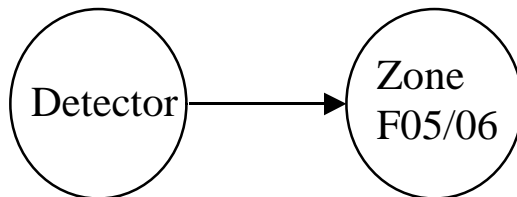

Nominal Detector Sensitivity

Using alarm sensitivities below 0.50% obscuration requires a 90-day test to ensure the detector environment is suitable for the higher sensitivity setting. Test each detector planned to operate below 0.50% obscuration as follows:

- 1. Set the detector as follows:
 - a) Initially set to the 0.50% obscuration alarm level
 - b) Set the Pre-Alarm level to the desired final alarm sensitivity.
 - c) Set the Pre-Alarm to “Alert” mode (non-latching)
- 2. Operate the detectors for 90 days with all environmental factors, record all events for each tested detector with an electronic history file or a printer.
- 3. At the end of 90 days check the history file for any alarms or pre-alarms, if no alarms or pre-alarms are shown, reprogram the fire alarm system to set the alarm sensitivity to the more sensitive pre-alarm level.

Self Optimising Pre-Alarm

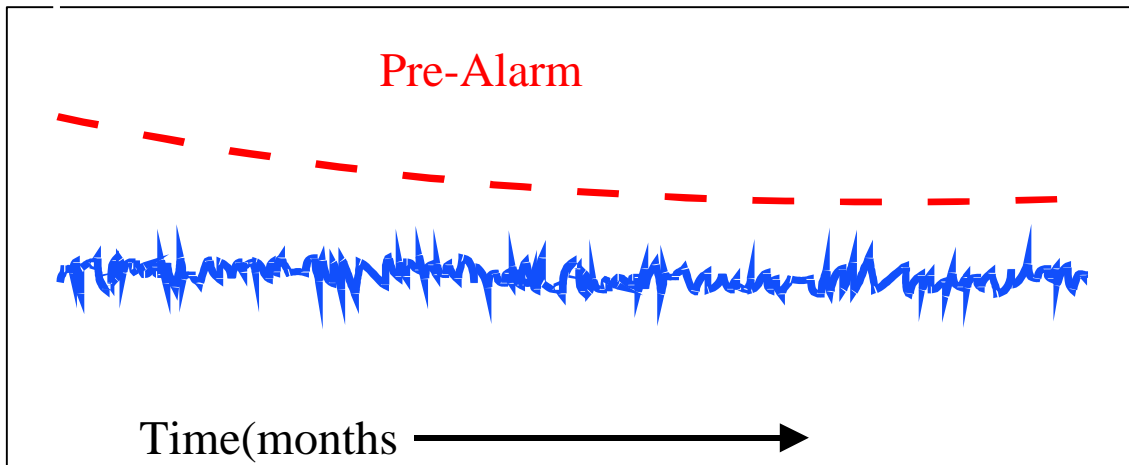

Selectable by Detector Sets Pre-Alarm just above normal peaks

Pre-Alarm - an indication from the control panel that a Detector is reaching an alarm level. The control Panel can provide an Alert or an action signal when a pre-alarm condition occurs.

Sensitivity Levels for the AFP-400: (Graph)

Photo Optical Alarm Sensitivity

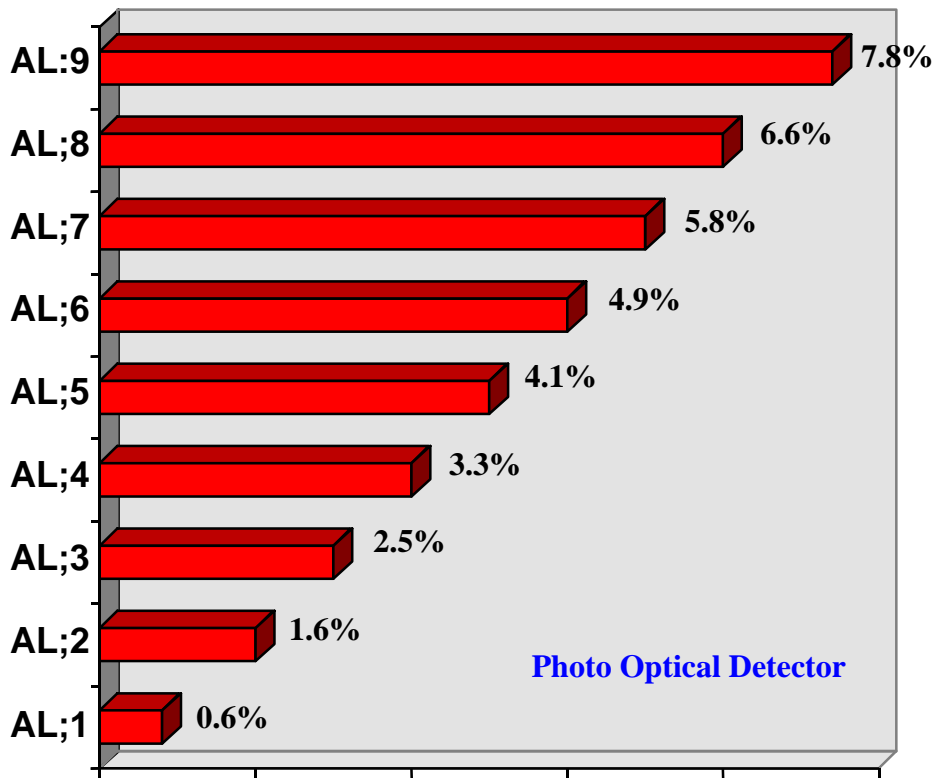
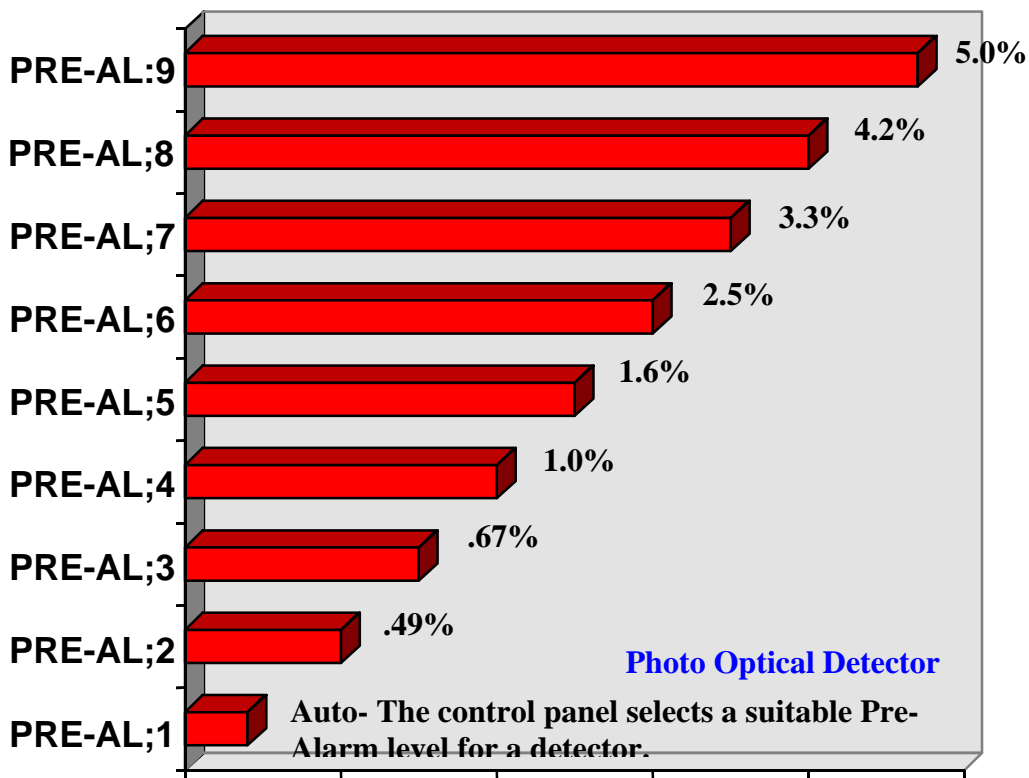

Photo Optical Pre-Alarm Sensitivity



Sensitivity Levels- Autoprogram Default Tables:

Photo Optical Detectors		
Description		
*Indicates the Default level setting, Between 1 and 9.		
Level	Alarm	Pre-alarm
0	Not Used	No Pre-Alarm
1	0.67%	Auto
2	1.67%	0.50%
3	2.50%	0.67%
4	3.33%	1.00%
5	4.16%	1.67%
6	5.00%	2.50%
7	5.83%	3.33%
8*	6.66%	4.16%
9	7.83%	5.00%

Laser Detectors		
Description		
*Indicates the Default level setting, Between 1 and 9.		
Level	Alarm	Pre-alarm
0	Not Used	No Pre-Alarm
1	0.10%	Auto
2	0.17%	0.07%
3	0.33%	0.10%
4	0.67%	0.17%
5	1.00%	0.33%
6*	1.33%	0.67%
7	1.67%	1.17%
8	2.50%	1.33%
9	3.33%	1.67%

Ionisation Detectors		
Description		
*Indicates the Default level setting, Between 1 and 9.		
Level	Alarm	Pre-alarm
0	Not Used	No Pre-Alarm
1	1.67%	Auto
2	2.50%	1.33%
3	3.33%	1.83%
4	4.16%	2.50%
5	5.00%	3.33%
6*	5.83%	4.16%
7	6.66%	5.00%
8	7.49%	5.83%
9	8.33%	6.66%

Multi Sensor Detectors		
Description		
*Indicates the Default level setting, Between 1 and 9.		
Level	Alarm	Pre-alarm
0	Not Used	No Pre-Alarm
1	2.50%	Auto
2	2.50%	1.67%
3	3.33%	1.67%
4	3.33%	3.33%
5*	6.66%	3.33%
6	9.99%	6.66%
7	9.99%	6.66%
8	13.32%	9.99%
9	13.32%	9.99%

Note:

If Multi-Detector mode is selected then the group detector sensitivity can be reduced down to .58% of the original alarm setting.

For additional programming assistance please contact your supplier.