



NOTIFIER[®]
by Honeywell

9 Columbia Way
Baulkham Hills, NSW 2153
PH 02-9894-1444 • FAX 02-9894-4193
www.notifier.com.au

Alarm Acknowledgement Module (AAM) Product Installation Document

25/01/2011 Rev: 1.00

DOC-03-038 ECN11-0192

1. Product Overview

The Sole Occupancy Unit – Alarm Acknowledgement Module (AAM) is part of a system that is intended to reduce the transmission of nuisance alarms to the Fire Brigade & the general premises. It provides facilities which allow an initial local pre-alarm warning sounder in the sole occupancy unit and a further facility to acknowledge the pre-alarm and initiate a time delay to investigate the cause of pre-alarm. This facility allows the occupant an opportunity to clear any nuisance alarm before it is broadcasted to the fire brigade. There are two types of Loop powered AAM's:

1. AAM with Switch & LED
2. AAM with switch only

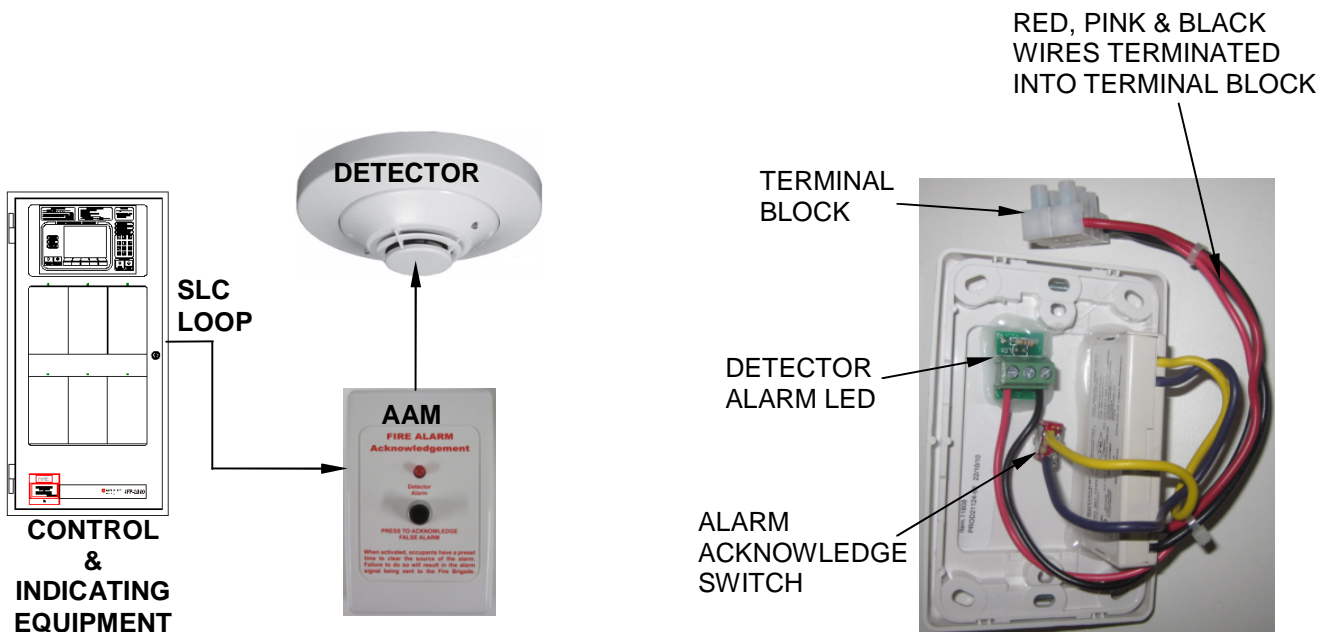

Figure 1, AAM with Switch & LED Overview

2. Installation



WARNING: Installation should be performed by competent persons in accordance with the relevant standards as required for the installation. Honeywell Ltd accepts absolutely no liability for the suitability, placement or settings of AAM within an installation.

1. Connect the Red wire (+) and the black wire (-) to the positive & negative terminals on the Terminal Block of the AAM.
Connections between AAM, Control & Indicating Equipment and Detectors using SLC loop cable should be done as per following connection diagrams outlined in Figure 2 & Figure 3.

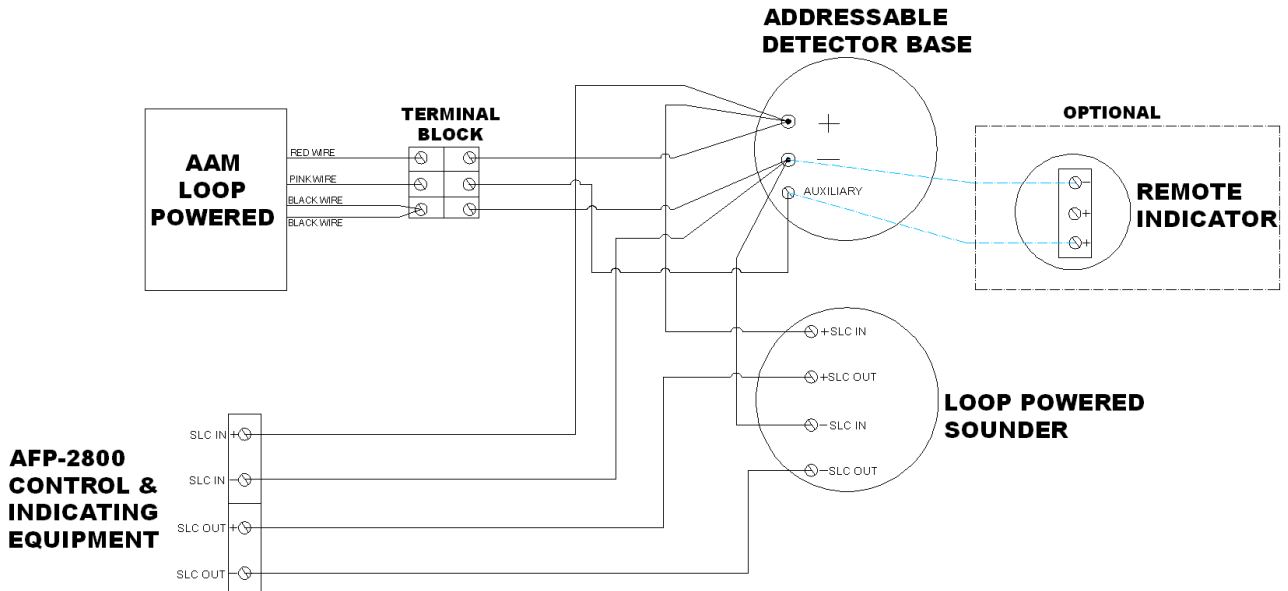

Figure 2, AAM with Switch & LED Connection Diagram

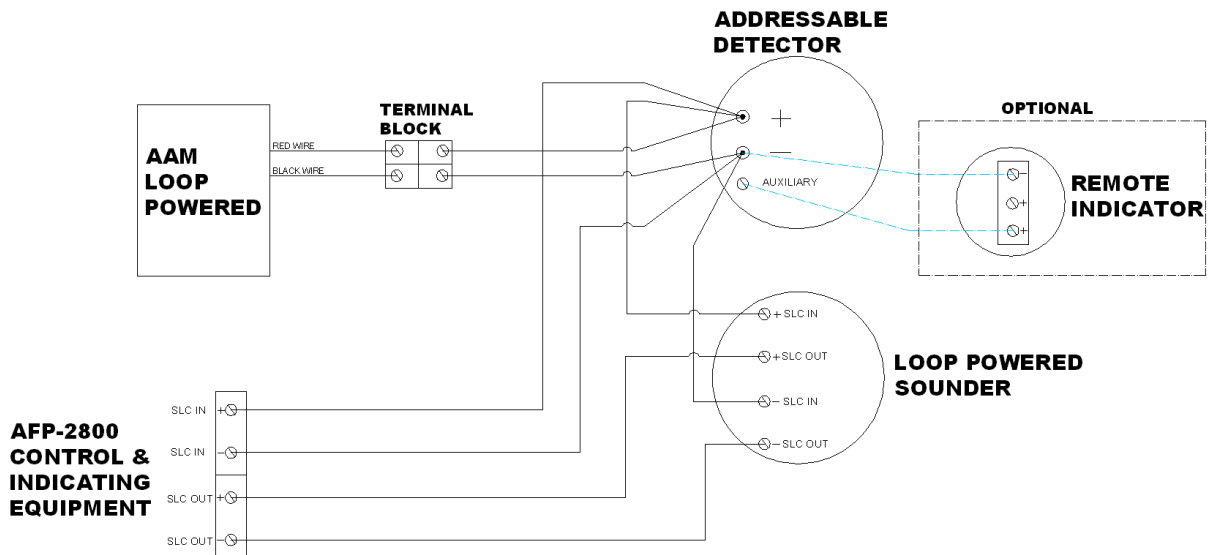

Figure 3, AAM with Switch only Connection Diagram

3. Components

The AAM kit assembly requires following components, as outlined in Table 1.

Part No.	Description	Qty
FG-05-009	Vertical AAM with Switch	1
FG-05-010	Vertical AAM with Switch & LED	
FG-05-014	Horizontal AAM with switch & LED	
DOC-03-038	AAM Product Installation Sheet Rev 1.00	1

Table 1: Components for AAM Assembly Kit

4. Supplemental Documentation

For information on...	Refer to...	Part No.
AAM	AAM – Operator’s Manual Rev 1.01	DOC-01-019

Table 2: Supplemental Documentation